

AQUATO[®] K-PILOT 14.5 Control Unit



PLEASE NOTE THE FOLLOWING:

The operating manual and the operating diary must be kept directly at the facility, so that both operators and qualified personnel can inspect it at any time.

Manufacturer

AQUATO® Umwelttechnologien GmbH

Ernstmeierstr. 24

D-32052 Herford

All rights reserved.

Violations shall give rise to claims for damages.

Reproduction and disclosure to third parties only with the manufacturer's approval.

I Table of Contents

I Table of Contents	3
II List of Figures	7
1 Manufacturer’s Declaration	8
2 Important Information	9
2.1 General Information	9
2.2 Important Notes	9
3 Safety Instructions	12
3.1 General Information on Safety Instructions	12
3.2 Definition of Terms.....	12
3.3 Hazard Analysis.....	12
3.4 Warning Symbols Used	13
3.5 Duty of Care of the Operator	13
3.6 General Safety Instructions.....	14
3.7 Safety Instructions for Qualified Personnel	15
3.8 Rescue Measures	15
4 Application Range of the Control Unit	16
4.1 Default Settings	17
4.2 Operation as an SBR Plant.....	17
4.2.1 Operation with Clear Water Pump.....	17
4.2.2 Operation with Dual Float Switch	17
4.2.3 Operation with Float BP	17

5	Installation Instructions for the Control Unit	18
5.1	Safety Instructions	18
5.2	Installation of the K-Pilot 14.5 Control Unit.....	19
5.3	Solenoid Valves and Cube Connectors.....	20
6	Connections on the Control Unit	21
6.1	Overview.....	21
6.2	Air Connections	23
6.3	Pressure Monitoring.....	24
6.4	Electrical Connections	25
6.4.1	Mains Connection of the Control Unit.....	27
6.4.2	Compressor	28
6.4.3	Potential-Free Contact	29
6.4.4	Operation with Solenoid Valves	31
6.4.5	Additional Connections – Operation with Motor Pumps.....	32
6.4.6	Float Switch	33
6.4.7	Clear Water Pump	37
7	Commissioning of the Plant.....	38
7.1	Before Commissioning.....	38
7.2	Commissioning	39
8	Operation and Displays of the Control Unit	40
8.1	Operation.....	40
8.2	Faults.....	41
8.3	Power Failure Alarm	42

9	Operation as an SBR Plant.....	43	SBR
9.1	Commissioning of the Control Unit.....	43	
9.2	Main Display	45	
9.3	Menu.....	46	
9.3.1	Menu Structure	46	
9.3.2	“Service” Menu	47	
9.3.3	“Settings” Menu	53	
9.3.4	Additional Menus with Displays or Settings.....	56	
9.4	Default Settings	62	
9.5	Switching Times – Basic Settings	62	
10	Operation as a Fluidized-Bed or Fixed-Bed Plant.....	63	MBBR / FBBR
10.1	Commissioning of the Control Unit.....	63	
10.2	Main Display	65	
10.3	Menu.....	66	
10.3.1	Menu Structure	66	
10.3.2	“Service” Menu	67	
10.3.3	“Settings” Menu	73	
10.3.4	Additional Menus with Displays or Settings.....	76	
10.4	Default Settings	79	
10.5	Switching Times – Basic Settings	79	
11	Operation as a Trickling Filter Plant	80	TF
11.1	Commissioning of the Control Unit.....	83	
11.2	Main Display	85	
11.3	Menu.....	86	
11.3.1	Menu Structure	86	

TF	11.3.2	“Service” Menu	87
	11.3.3	“Settings” Menu	92
	11.3.4	Additional Menus with Displays or Settings.....	95
	11.4	Default Settings	97
CW	12	Operation as a Constructed Wetland Wastewater Treatment Plant	98
	12.1	Commissioning of the Control Unit.....	99
	12.2	Main Display	101
	12.3	Menu.....	102
	12.3.1	Menu Structure	102
	12.3.2	“Service” Menu	103
	12.3.3	“Settings” Menu	108
	12.3.4	Additional Menus with Displays or Settings.....	111
	12.4	Default Settings	113
	13	Error Messages and Troubleshooting	114
14	Technical Data.....	116	
15	Operating Log	117	
16	Decommissioning and Disposal	118	
16.1	Temporary Decommissioning	118	
16.2	Dismantling of the Complete Plant	118	
16.3	Disposal.....	118	
17	Addresses	119	

II List of Figures

Figure 1: K-Pilot 14.5 control unit	16
Figure 2: Connections on the K-Pilot 14.5 control unit.....	21
Figure 3: K-Pilot 14.5 control unit opened	22
Figure 4: Connection for pressure measurement on and in the control unit	23
Figure 5: Hose connection for pressure monitoring.....	24
Figure 6: External electrical connections on the K-Pilot 14.5 control unit	25
Figure 7: Electrical connections inside the K-Pilot 14.5.....	26
Figure 8: K-Pilot 14.5 control unit with socket for compressor.....	28
Figure 9: Potential-free contact	29
Figure 10: Potential-free contact with power supply from the control unit.....	30
Figure 11: Potential-free contact with fault message also in the event of power failure	30
Figure 12: K-Pilot 14.5 with cube connectors for connecting the solenoid valves	31
Figure 13: K-Pilot 14.5 additional connections in the control unit	32
Figure 14: K-Pilot 14.5 with connections for float switches.....	33
Figure 15: K-Pilot 14.5 – float switch connection.....	34
Figure 16: Connection of 2nd float switch as high-water alarm	35
Figure 17: Connection of dual float switch on K-Pilot 14.5	36
Figure 18: Clear water pump with external float switch	37
Figure 19: K-Pilot 14.5 control unit – clear water pump connection.....	37
Figure 20: Operating buttons.....	40
Figure 21: SBR menu structure	46
Figure 22: Menu structure for fluidized-bed or fixed-bed plant	66
Figure 23: Trickling filter plant with pumps	80
Figure 24: Menu structure for trickling filter C and trickling filter N	86
Figure 25: Menu structure for trickling filter C and trickling filter N	102

1 Manufacturer's Declaration

Declaration of Conformity

This certifies the conformity of the AQUATO® K-Pilot 14.5 control unit with the EU directives for CE marking.

Device type: **Electronic control units for the automatic operation of a fully biological small wastewater treatment plant in accordance with DIN 4261-2 and DIN EN 12566-3 AQUATO® K-Pilot 14.5**

Directives / Regulations:	1. 2014 / 30 / EU	EMC Directive
	2. 2014 / 35 / EU	Low Voltage Directive
	3. 2011 / 65 / EU	RoHS Directive
	4. 2006 / 42 / EC	Machinery Directive
	5. 305 / 2011	Construction Products Regulation

Applied standards:

re 1.	EN 61000-6-3 (2006) EN 61000-6-1 (2007) EN 61000-3-2 (2014)
re 2.	EN 60204-1 (2010)
re 3.	-not applicable -
Special notes:	- none -

This letter certifies conformity with the directives listed above, but does not constitute any guarantee of properties. The Declaration of Conformity loses its validity if the product is modified without the manufacturer's approval.

Date: 15.06.2021

Nils Homburg, Technical Manager

Manufacturer: **AQUATO®
Umwelttechnologien GmbH
Ernstmeierstraße 24
32052 Herford**

2 Important Information

2.1 General Information

This manual describes the operation of the K-Pilot 14.5 control unit.

With the AQUATO® K-Pilot 14.5 control unit, you receive a quality product designed for controlling small wastewater treatment plants. For this purpose, compressors and pumps are controlled automatically. During operation, the units are monitored for current and pressure in order to ensure operational safety.

The K-Pilot 14.5 control unit can be used to operate SBR, fixed-bed and fluidized-bed plants, as well as trickling filter and constructed wetland wastewater treatment plants.

Please read this information in advance in order to ensure proper operation and permanent compliance with the required discharge values.



The complete operating manual must be kept directly at the plant so that both the operator(s) and qualified specialist personnel, such as the maintenance company, can consult it at any time.

2.2 Important Notes

Faults are indicated acoustically and visually by the AQUATO® K-Pilot 14.5 control unit. It is equipped with mains-independent power failure monitoring.

After commissioning has been completed, have yourself instructed in the plant technology and the function of the AQUATO® K-Pilot 14.5 control unit.

Improper use will void the warranty!

For repairs, proper function and preservation of the warranty can only be guaranteed if original spare parts or spare parts approved by AQUATO® are used.



The small wastewater treatment plant must be in continuous operation. It must not be switched off.

If you have problems with your control unit, contact your maintenance company. They will be happy to help you solve the problem.

If the AQUATO® control unit is used for other purposes without the express approval of AQUATO® Umwelttechnologien GmbH and/or if the safety instructions are disregarded, this may endanger or injure persons and may lead to malfunctions or defects in the plant.

In this case, any liability is excluded.



The relevant accident prevention regulations must be observed.

Modifications to the control unit or unauthorized conversions are not permitted.

The AQUATO® K-Pilot 14.5 control unit must be properly installed before use and in accordance with the installation instructions; see Chapter 5.

The operating manual for the control unit must be read carefully before installation and commissioning, and the instructions contained therein must be strictly followed.

The applicable standards and regulations must be observed during assembly and installation, commissioning and operation, and, if applicable, decommissioning.

All work may only be carried out by trained specialists with the corresponding proof of professional qualification.

The operator of the plant must be instructed in its operation by the installer.

When connecting the control unit, the nationally applicable regulations and the information on the type plate must be observed. The device may only be operated on mains systems that include a protective conductor (PE). Connection to the power supply must be carried out with separate fuse protection and a residual current device (RCD). Before commissioning, the proper function of the electrical protective measures must be checked.

Installation work may only be carried out by qualified electricians.

When work is carried out on the device, the mains plug must always be disconnected.

Do not operate any device that

- ▶ has malfunctions,
- ▶ has been dropped,
- ▶ has been damaged in any other way,
- ▶ obviously has a damaged connection/interconnecting cable, or
- ▶ obviously has a damaged plug.

During all maintenance and repair work, the plant must be disconnected from the power supply.

If it is necessary to enter the plant, this may only be done in the presence of a second person and with appropriate safety measures, such as a gas warning device and safety lines.

The applicable accident prevention regulations and recognized rules of technology must be observed.

3 Safety Instructions

3.1 General Information on Safety Instructions

This manual contains basic instructions that must be observed during installation, commissioning and maintenance.



The complete manual must be kept directly at the plant so that both the operator(s) and qualified specialist personnel, such as the maintenance company, can consult it at any time.

The safety instructions listed in this operating manual, the existing national regulations on accident prevention and any internal work, operating and safety regulations must always be observed.

Failure to observe the safety instructions may pose a hazard to both persons and the environment and may result in the loss of any claims for damages.

3.2 Definition of Terms

Operator

The operator of the plant is the person who ensures that the plant is operated in a functional condition.

Qualified Specialist Personnel

Qualified specialist personnel are able, on the basis of their professional training and the knowledge and skills acquired, to assess and carry out assigned work and to recognize and assess hazards.

3.3 Hazard Analysis

The AQUATO® plants have been developed according to the state of the art and subjected to a hazard analysis. To eliminate or minimize risks, please observe the following instructions.

3.4 Warning Symbols Used

Below you will find an overview of the symbols used in this manual and their meaning:



Warning of a danger point



Warning of dangerous electrical voltage

3.5 Duty of Care of the Operator

Ensure that

- the plant is used only for its prescribed intended purpose; see Chapter 4,
- the plant is operated only when it is in proper working order,
- self-checks are carried out by the operator,
- the maintenance intervals are observed,
- maintenance and repairs are carried out only by qualified specialist personnel,
- the operating manual for the control unit, as well as the installation, operating and maintenance manual and the operating log, can be consulted at any time,
- only wear parts and spare parts approved by the manufacturer are used.

3.6 General Safety Instructions

The accident prevention regulations for work on wastewater engineering plants (DGUV Regulation 21 and DGUV Regulation 22) must be observed. The respectively applicable regulations (EN, VDE, etc.) as well as the regulations of the local energy supply companies must be strictly complied with. The work should only be carried out by qualified personnel. The following safety instructions must always be observed for your own safety when working on or coming into contact with the small wastewater treatment plant:



1. Disconnect the small wastewater treatment plant from the power supply!

Special care is required during maintenance work in the pit. In this case, the plant technology must always be disconnected from the power supply and secured against unintended restoration of the power supply.



Risk of electric shock in the event of a defective compressor or defective power cables.

The AQUATO® aeration plants generate a water/air bubble mixture during fine-bubble aeration, which has a lower density than pure water. This reduces buoyancy in the water. If a person accidentally falls into the reactor, it would not be possible for that person to swim. **Risk of drowning!**



2. Ventilate the plant well; entry into the pit only with safety precautions and a supervising person!

Biological processes produce gases that are dangerous to humans. These can lead to unconsciousness and/or death by suffocation, even if they cannot be detected by smell. Entry into the small wastewater treatment plant is therefore only permitted under the supervision of a person standing watch outside and after thorough ventilation, with appropriate safety measures such as a gas warning device and safety lines.

A rescue/fall-arrest harness must be worn by every person entering the plant. Never climb in after unconscious persons; call for help immediately!



3. Electrical protection, residual current device (RCD)!

The AQUATO® plants operate with 230 V / 50 Hz AC voltage or with 400 V / 50 Hz AC voltage. When operating the control unit, personnel must not be exposed to the risk of electric shock, even through carelessness, e.g. wet fingers. The socket intended for the control unit must be separately protected by a residual current device (RCD) in accordance with DIN VDE 0100-410:2018-10 and must have been connected to the power supply by electrically qualified personnel. Before commissioning the plant, the proper function of the electrical protective measures must be checked by an approved qualified electrician.



3.7 Safety Instructions for Qualified Specialist Personnel

Installation, maintenance work and repairs may only be carried out by qualified specialist personnel. Before carrying out the work, it must be ensured that

- the knowledge and skills of the personnel correspond to the intended task
- the personnel have received instruction,
- the **operating manual** has been read and understood.



Before and during work in the tank, ventilation must be used to ensure that neither gases in concentrations hazardous to health, nor an explosive atmosphere, nor a lack of oxygen can occur. Entry into the tank may only take place in the presence of a second person and with appropriate safety measures, such as a gas warning device and safety lines.



Before and during the work, it must be ensured that the plant has been disconnected from the power supply and secured against being switched on again.



Work in tanks requires protective measures even at low heights. Suitable measures must therefore be taken to prevent falls. If technical measures are not possible, personal protective measures against falling should be used.



Always wear suitable protective clothing as well as hand, foot and face protection.
Avoid contact with wastewater.

We would like to point out that, despite all safety measures taken, residual risks at the installation site cannot be excluded:

- **risk of slipping and tripping**
- **danger due to electrical voltage**
- **risk of infection from germs and bacteria**

3.8 Rescue Measures

Ensure that a second person is always available for safety when work is carried out in the tank. Never climb in after an unconscious person; call for help.

4 Application Range of the Control Unit

The K-Pilot 14.5 control unit is used to operate small wastewater treatment plants. The control unit has an integrated power failure warning as well as current and pressure monitoring.

This control unit can be used to operate SBR, fixed-bed and fluidized-bed plants, as well as trickling filter wastewater treatment plants.

As standard, treatment class C is provided for fixed-bed, fluidized-bed, trickling filter and constructed wetland wastewater treatment plants, and treatment classes C and D are provided for SBR wastewater treatment plants.

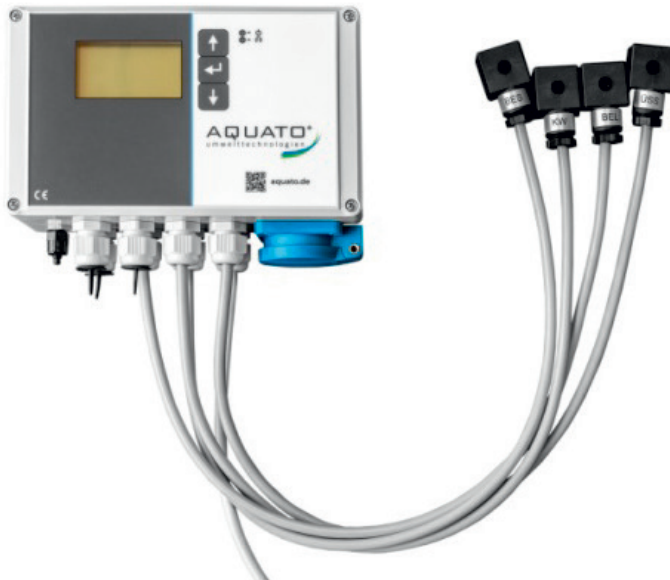

Figure 1: K-Pilot 14.5 control unit

The K-Pilot 14.5 control unit has five electrical outputs and two float switch inputs. This means that a wide variety of combinations of units for operating the plant are possible with this control unit.

4.1 Default Settings

The control unit can be operated both without and with a float switch. If a float switch is used, the clear water discharge time is shortened where possible and, if necessary, a high-water alarm is triggered. In addition, energy-saving operation with slightly reduced runtimes is possible for SBR plants.

As standard, all required pumping processes in SBR, fixed-bed and fluidized-bed plants are carried out using compressed-air lifts.

In trickling filter and constructed wetland wastewater treatment plants, submersible motor pumps are controlled by the control unit as standard.

A float switch used purely as a high-water alarm, without affecting the cycle, can also be used with the K-Pilot 14.5 control unit in SBR, fixed-bed and fluidized-bed plants.

4.2 Operation as an SBR Plant

In addition to the standard operating modes, further functions can also be controlled.

4.2.1 Operation with Clear Water Pump

When operating with the K-Pilot 14.5 control unit, the clear water airlift can be replaced by a submersible motor pump.

4.2.2 Operation with Dual Float Switch

With the K-Pilot 14.5 control unit, it is possible to operate with a dual float switch, i.e. to use one float switch for the lower switching point and another for the upper switching point, thereby increasing the buffer volume. In this case, however, no further float switch can be used for an additional buffer.

4.2.3 Operation with Float BP

The Float BP function is intended for SBR plants that have a float switch with very small hysteresis installed. With the Float BP setting, the float switch intervenes in the SBR cycle by ending feeding when it floats up, but it does not end clear water discharge when the float switch drops. However, an HW alarm is still triggered if the float switch has not dropped after clear water discharge.

5 Installation Instructions for the Control Unit

5.1 Safety Instructions



Failure to comply with the following safety instructions may result in restricted or complete loss of the manufacturer's liability.

The control unit is intended for cabinet installation.



Do not insert the mains plug until the existing units have been connected to the devices provided for this purpose in the control unit.

Have the electrical installation carried out only by qualified specialist personnel. The manufacturer accepts no liability for damage caused by carrying out the installation yourself.



Interventions in the device and repairs of any kind may only be carried out by qualified personnel.



Before and during the work, it must be ensured that the plant has been disconnected from the power supply and secured against being switched on again.

Before commissioning and switching on the mains voltage, ensure that

- the device and the connecting cables show no visible damage,
- in particular, the mains connection and the connections of the units are properly connected,
- all connections have been carried out properly and professionally,
- the routing/execution of all cables and lines complies with the applicable regulations,
- the device is properly closed,
- the plant is properly protected. Mains-side protection max. 1 x 16 A G.

Observe the following important instructions before working on the control unit:

- Disconnect the plant from the mains before opening the control unit. Pull out the mains plug.
- Open the control unit carefully and do not simply let the cover fall, in order to avoid tearing off or damaging cables or hoses.
- Replace individual fuses only when the device is de-energized.
- Never use fuses with higher current ratings than specified.
Do not make any circuit-related modifications to the plant.

- The respectively applicable regulations (EN, VDE, etc.) as well as the regulations of the local energy supply companies must be strictly observed.
- If a fuse is defective, it may only be replaced with a fine-wire fuse of the same type. In the standard case with one compressor, a fuse of the following type is installed at the factory: **fine-wire fuse, time-lag type 3.15 A, 5 x 20 mm** in accordance with EN 60127-2/III, with a maximum power dissipation of 1.5 W. In a 2-compressor plant, the following type is used: fine-wire fuse, time-lag type 5 A, 5 x 20 mm.



Note:

In larger plants, a stronger fuse may be installed (max. 6.3 A T). Always replace fuses with a fuse of the same current rating.



Disconnect the mains plug when working on the control unit, pumps and/or compressors.

The cables to the device must be installed properly. In particular, care must be taken to avoid major mechanical loads on the cables, e.g. due to insufficiently fixed cables, as otherwise degree of protection IP 54 cannot be guaranteed.

5.2 Installation of the K-Pilot 14.5 Control Unit

With the control unit, you can control different wastewater treatment processes with different equipment configurations. The valves required for this are arranged outside the housing.

The control unit can be mounted on a wall or on a mounting plate.

When installed in a wall cabinet, the control unit is mounted on the rear wall of the wall cabinet. The compressor is installed in the wall cabinet on site.

If an outdoor wall cabinet or an outdoor column is used, place it in a shaded and wind-protected location. In climatically unfavourable locations, it may be necessary to install a heater and/or a cooling fan. If a larger diaphragm compressor or a rotary vane or side-channel compressor is used, a cooling fan is required.

- Before commissioning the control unit, **please read this manual as well as the manual for the respective process**, in particular the chapters “**Safety Instructions**”, “**Commissioning of the Control Unit**” and “**Selecting Plant Types**”.
- When selecting the installation location, the weight of the finished unit, here for example approx. 20 kg, must be taken into account.
- A building structure that transmits sound or vibrations is unsuitable for installation.

- The installation location must be dry, clean and well ventilated. High levels of dust must be avoided, as otherwise the air filter of the compressor may become clogged.
- Mount the wall cabinet plumb and level on the wall.
- Place the compressor on the floor of the wall cabinet and connect the air outlet to the valve block.
- Connect the required units to the control unit terminals.
- Insert the plug for the compressor power supply into the 230 V socket at the bottom of the control unit.

If the control unit has to be opened, disconnect the plant from the mains before opening the control unit. Open it carefully and do not simply let the cover fall, in order to avoid tearing off or damaging cables or hoses.



Caution:

Direct sunlight must be avoided in all installation variants. Place the control unit in a shaded and wind-protected location. In climatically unfavourable locations, install a heater and/or cooling fan. Install a cooling fan for larger compressors.

5.3 Solenoid Valves and Cube Connectors

The air is routed from the compressor to the valve block. The solenoid valve block is generally located in the wall cabinet. The solenoid valves are controlled by the control unit using the cube connectors in order to open or close the valve for the respective function, depending on the plant type and configuration, e.g. clear water discharge, sludge return, feeding, aeration, so that the air is available for the function required in each case. The cube connectors are labelled according to their function with "AER" (= aeration), "FED" (= feeding), "CW" (= clear water discharge) and "ESS" (= excess sludge return).

In trickling filter and constructed wetland wastewater treatment plants, the units are connected directly to the terminals in the control unit; see Chapters 4 and 6.4.5.

6 Connections on the Control Unit

6.1 Overview

The display and operating buttons are located on the front of the K-Pilot 14.5 control unit.

The connection for the mains cable, the socket for the compressor, cable entries for the units to be connected and a connection for pressure measurement are located on the underside of the control unit.

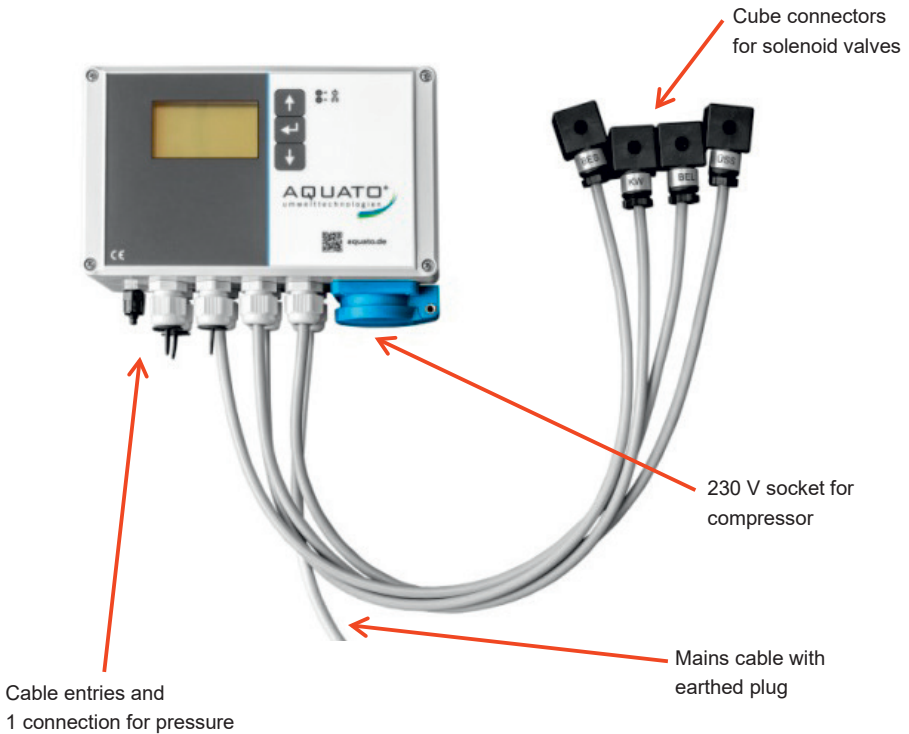

Figure 2: Connections on the K-Pilot 14.5 control unit

Inside, the terminals for the electrical outputs and inputs are located on the rear wall of the control unit. The float inputs are permanently assigned.

On the PCB, the potential-free contact is arranged on the side. Diagonally opposite is an RS232 serial interface.

The fine-wire fuse and the batteries are also mounted on the PCB.

Other important components are the relays and the pressure sensor.

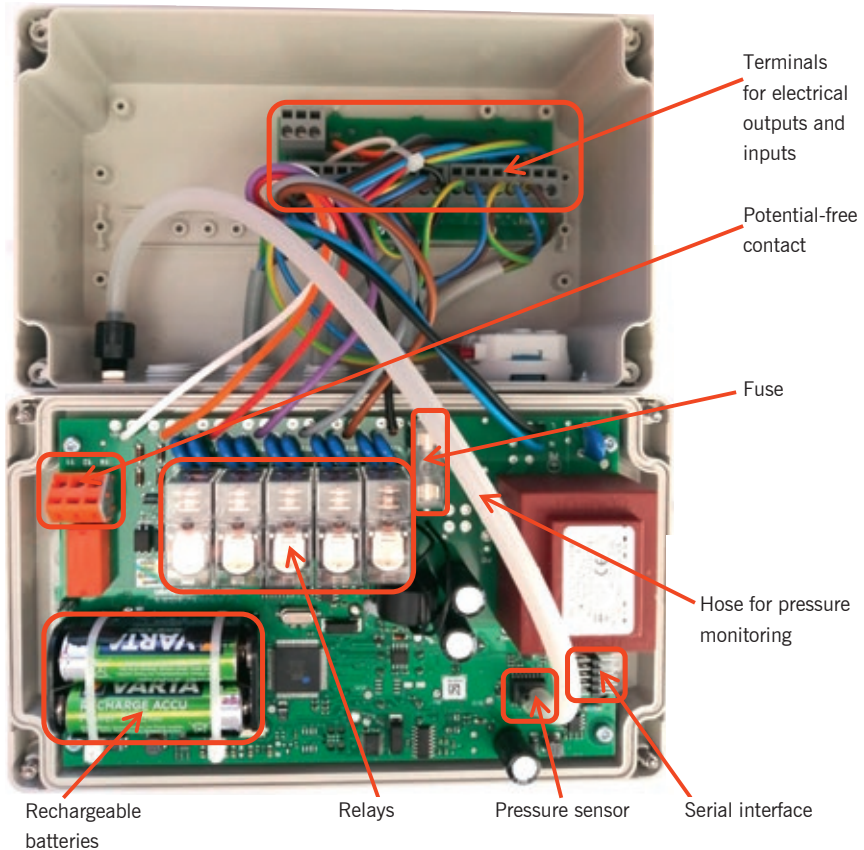

Figure 3: K-Pilot 14.5 control unit opened

6.2 Air Connections

The air from the compressor is distributed via **solenoid valves** in the control cabinet, which are controlled by the control unit, in such a way that the different functions are ensured.

The K-Pilot 14.5 control unit itself has only one air connection. This is used for pressure measurement in the control unit. For pressure monitoring, the control unit is equipped with a pressure sensor. A hose is routed from this sensor to the housing of the control unit. The hose connection is a 4 mm fitting. A 4 mm hose must be connected to this connection on the housing and connected to the air line between the compressor and the valves.

The hose connection for pressure measurement is located on the underside of the control unit; see Figure 4.

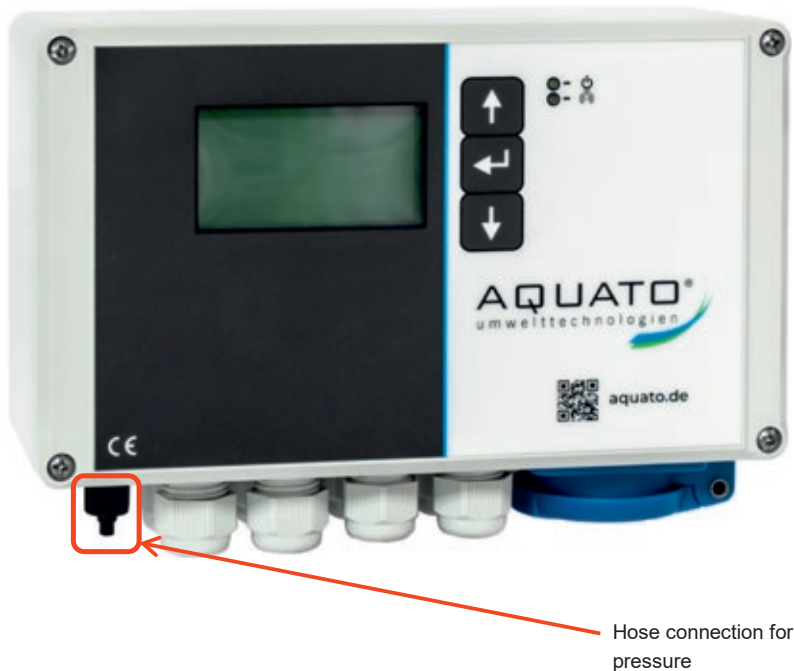

Figure 4: Connection for pressure measurement on and in the control unit

6.3 Pressure Monitoring

For pressure monitoring, the control unit is equipped with a pressure sensor. A hose is routed from this sensor to the housing of the control unit. The hose connection is a 4 mm fitting. A 4 mm hose must be connected to this connection on the housing and connected to the air line between the compressor and the valves.



Figure 5: Hose connection for pressure monitoring

If there is no connection option for pressure monitoring on the plant between the compressor and the valves, the pressure monitoring of the control unit must be switched off during commissioning or afterwards in the "Select Plant Type" menu.

6.4 Electrical Connections

The electrical connections for the valves to be connected are routed out of the control unit and are already fitted with cube connectors. The cube connectors are marked “AER” for aeration, “FED” for feeding, “CW” for clear water discharge and “ESS” for excess sludge discharge.

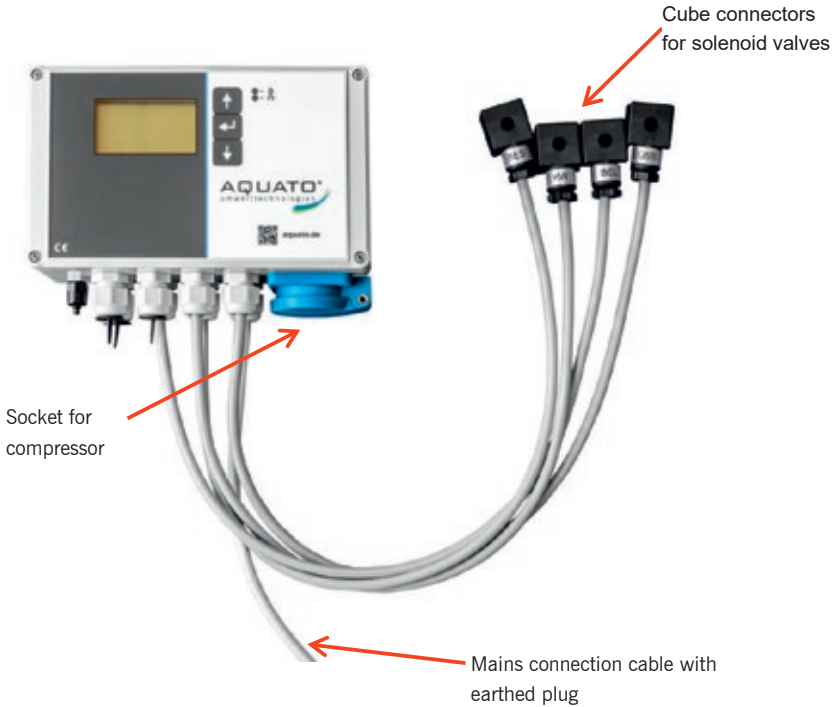

Figure 6: External electrical connections on the K-Pilot 14.5 control unit

The electrical connections for the float switch(es), as well as the outputs for controlling the units, such as valves, pumps, etc., are located in the terminal compartment inside the housing on the small PCB on the rear wall of the control unit.

The potential-free contact is located on the large PCB inside the housing of the control unit.

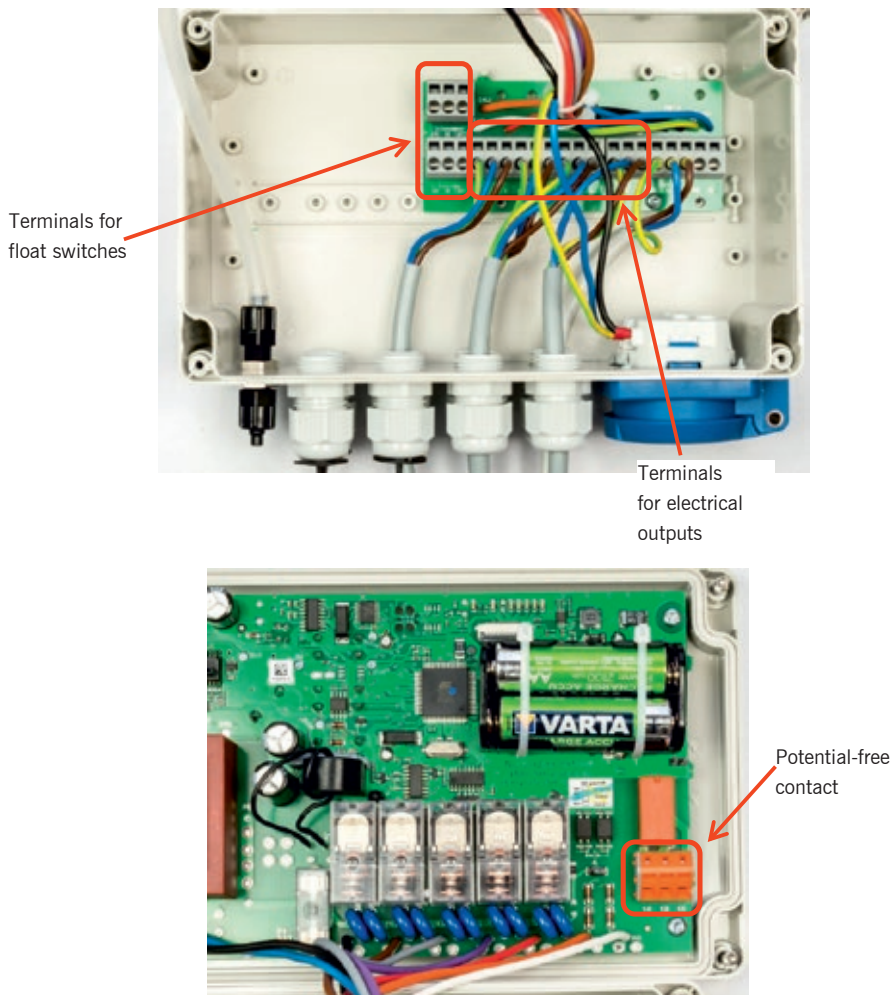

Figure 7: Electrical connections inside the K-Pilot 14.5

6.4.1 Mains Connection of the Control Unit

A 230 V / 50 Hz power supply cable must be provided on site to the location of the control unit. This must be separately protected with a B 16 A time-lag fuse and a residual current device (RCD) 25 A / 30 mA. A mains disconnecting device must be used for connecting the control unit.

The mains connection is made using the supplied connection cable with earthed plug, length approx. 1.5 m. This is fixed to the control unit by means of an M20 cable gland. The control unit may only be used on a 230 V / 50 Hz +/-10 % power supply. The plant must be protected on the mains side by means of a residual current device (RCD) and fuse.

All protective devices must be checked for proper function before commissioning.

Before inserting the mains plug, i.e. before commissioning the plant, the treatment tank(s) must be filled with water up to 5 cm above HW_{min} and all required units, e.g. compressor and airlifts, must be connected.

After the plug has been inserted, the control unit starts with a self-test lasting approx. 3 seconds and the display "booting system...". The start message "AQUATO" then appears. The display Vx.xx.xx, e.g. V2.07.09, in the lower part of the message is the software version number. A few seconds later, the standard display appears. During commissioning, some settings are still required at this point; see Chapters 9.1 and 9.3.2.4 as well as Chapters 10.1 and 10.3.2.4. The device is now ready for operation.

When the compressor, or an optional other unit, is running, the LED lights up green. In the event of a fault/error, the LED flashes red.



Caution: Before commissioning the plant, the treatment tank(s) must be filled with water up to 5 cm above HW_{min} . In addition, the compressor and airlifts as well as any pumps and float switches must be connected.

6.4.2 Compressor

The compressor should be installed in the immediate vicinity of the control unit.

- Connect the air outlet to the air distribution system, e.g. solenoid valves, using the supplied 90° hose elbow and two hose clamps.
- The installation location must be dry, clean and well ventilated. High levels of dust must be avoided, as otherwise the air filter of the compressor may become clogged.
- Insert the plug for the compressor power supply into the 230 V socket of the control unit.

The compressor is connected by inserting the plug into the socket on the underside of the control unit; see Figure 8. Its runtimes are controlled via the connection through this socket.



Figure 8: K-Pilot 14.5 control unit with socket for compressor



Caution: The compressor must not be connected to an external socket, as in this case the aeration cycles will not be observed. It must be connected to the socket provided for this purpose on the underside of the control unit.

6.4.3 Potential-Free Contact

- 6.4.4 The control unit is equipped with a potential-free contact. This serves as an ON/OFF switch for the warning or operating status indication. It is located on the PCB at the side next to the relays. In addition to the warning signals of the control unit, a warning lamp/flashing light can be connected via this contact. This can be supplied with power via the control unit or via an independent external cable. In the event of **an alarm**, the relay closes the **connection between terminals 11 and 12** and opens the connection between terminals 11 and 14.

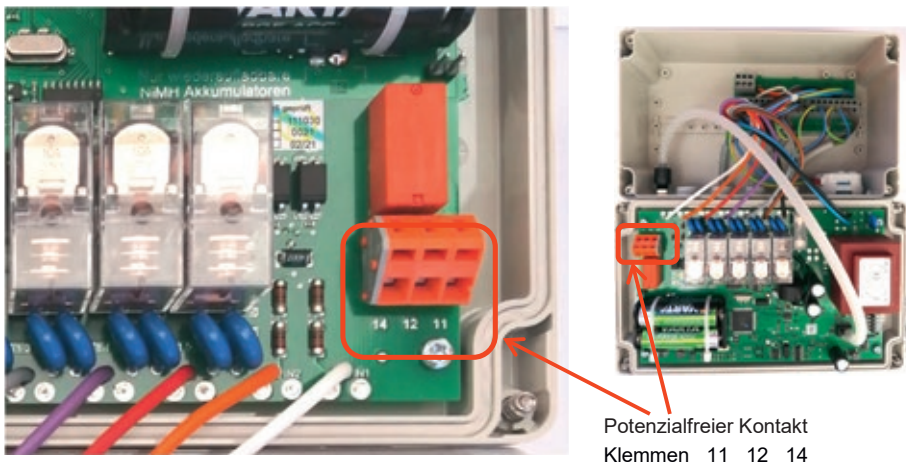

Figure 9: Potential-free contact

If an additional light is to be used as an operating status indication, connection to contacts 11 and 14 is provided.

If the warning lamp/flashing light is to light up/flash as a fault indication in the event of a fault, the connection via contacts 11 and 12 must be selected; see Figure 9, Figure 10, Figure 11.

Power supply from the same circuit as the control unit
 → No signal in the event of an RCD fault!

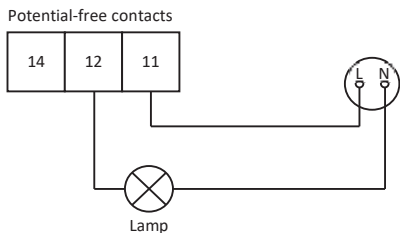

Figure 10: Potential-free contact with power supply from the control unit

Power supply from external circuit
 → Alarm also in the event of an RCD fault!

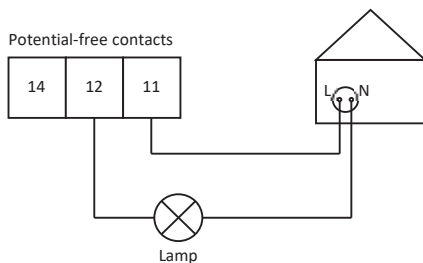

Figure 11: Potential-free contact with fault message also in the event of power failure

In order to maintain the additional warning signal even in the event of a power failure in the control unit, the warning lamp/flashing light must be connected to an external circuit; see Figure 11.

6.4.5 Operation with Solenoid Valves

For the K-Pilot 14.5 control unit, four cube connectors for connecting the solenoid valves to the control unit are supplied ready for connection, so that they only need to be plugged onto the corresponding valves.

The cube connectors are marked “AER” for aeration, “FED” for feeding, “CW” for clear water discharge and “ESS” for excess sludge discharge.

The required setting of the control unit can be found in the manual for the respective process.

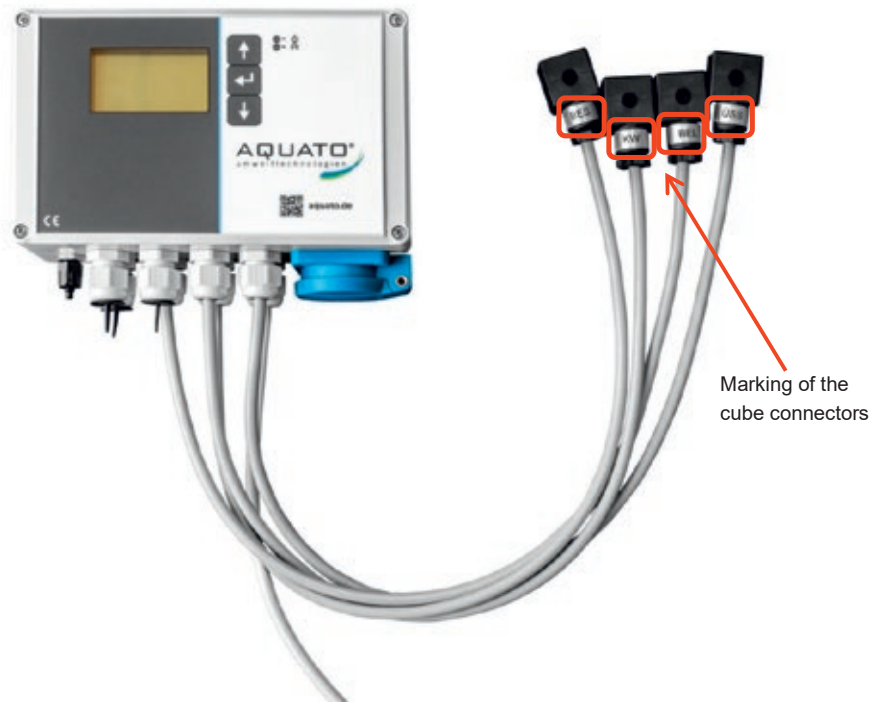

Figure 12: K-Pilot 14.5 with cube connectors for connecting the solenoid valves

6.4.6 Additional Connections – Operation with Motor Pumps

For the K-Pilot 14.5 control unit, four cube connectors for connecting the solenoid valves are supplied ready for connection, so that they only need to be plugged onto the corresponding valves.

If submersible motor pumps are used, they are connected to the output whose function they take over. In trickling filter and constructed wetland wastewater treatment plants, the pumps are connected directly to the terminals in the control unit.

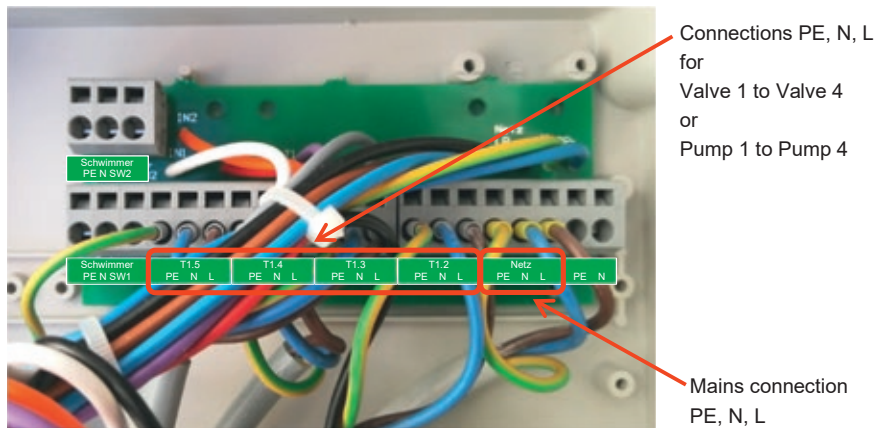

Figure 13: K-Pilot 14.5 additional connections in the control unit

The following Table 1 shows the assignment of the outputs on the PCB on the rear wall of the control unit. The assignment of the outputs is fixed and cannot be changed.

Marking of the outputs for	T1.2 PE N L Valve 1	T1.3 PE N L Valve 2	T1.4 PE N L Valve 3	T1.5 PE N L Ventil 4
Connectable unit SBR	ESS valve	CW valve / clear water pump	FED valve	AER valve
Connectable unit FB/WSB	ESS valve / sludge pump			
Connectable unit trickling filter	Pump 1 / feed pump	Pump 2 / discharge pump (= clear water pump)	Pump 3 / sludge pump	Pump 4 (time-cycled)
Connectable unit constructed wetland wastewater treatment plant	Pump 1 / feed pump	Pump 2 / discharge pump (≙ clear water pump)	Pump 3	Pump 4 (time-cycled)

Table 1: Assignment of the outputs

6.4.7 Float Switch

A float switch can optionally be used. The float inputs are permanently assigned. The float switch for the **“Float” control type** is connected to the K-Pilot 14.5 control unit at the terminals provided for this purpose, PE, N, SW1; for assignment, see Table 2; see Figure 14.

A normally open contact with control voltage is used as standard: 230 V~ approx. 5 mA, switching between input L and N.

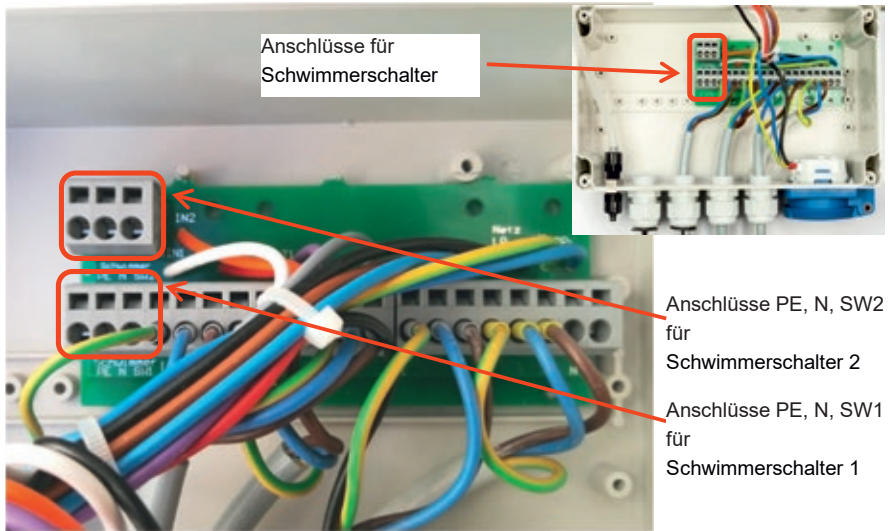

Figure 14: K-Pilot 14.5 with connections for float switches

Float input, PE, N, S1	Float input, PE, N, S2
Float switch for energy-saving operation with control type: Float and Float BP	Float switch for temporary high-water indication with control type: Float
Float switch for temporary high-water indication with control type: Time	Float switch 2 with control type: Dual Float
Float switch 1 with control type: Dual Float	SW 2 for trickling filter: high water in pump chamber
SW 1 for trickling filter: dry-running protection	SW 2 for constructed wetland wastewater treatment plant: high water in clear water discharge shaft
SW 1 for constructed wetland wastewater treatment plant: high water in feed shaft	

Table 2: Assignment of the inputs

6.4.7.1 Float Switch with “Float” Control Type

If the float switch for the **“Float” control type** is connected to the terminals “PE”, “N”, “SW1” provided for this purpose; see Figure 15, on the longer terminal block, and the “FLOAT” control type is selected during commissioning, this float switch controls the clear water discharge and the aeration times and triggers a high-water alarm.

When the float switch drops, it switches off the clear water discharge. If it does not drop by the end of the clear water discharge, it triggers a high-water alarm. If, after clear water discharge or the subsequent sludge discharge, it remains down until the end of the aeration time, the plant switches to energy-saving operation, with reduced runtimes of the units and no clear water discharge. When the float switch floats up again, energy-saving operation ends and the cycle continues with the aeration phase.

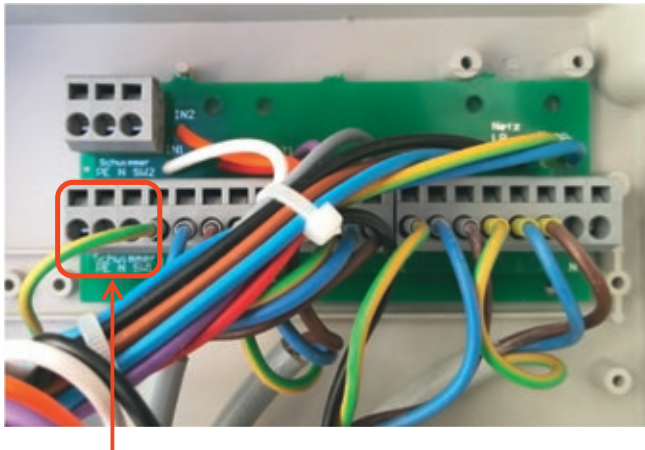

Anschluss für
Schwimmerschalter
in Steuerung K-Pilot 14.5
an Klemmen PE, N, SW1

Figure 15: K-Pilot 14.5 – float switch connection

6.4.7.2 Float Switch with “Time” Control Type as High-Water Alarm

If the **“Time” control type** option is selected and the float switch is connected to the terminal “PE”, “N”, “SW1” provided for this purpose; see Figure 15, on the longer terminal block, the float switch operates only as a high-water alarm without intervening in the cycle sequence. The float switch display for this float switch is then shown on the display only temporarily in the event of high water.

6.4.7.3 Second Float Switch as High-Water Alarm

If the float switch for the **“Float” control type** is connected to the terminal “PE”, “N”, “SW1” provided for this purpose on the longer terminal block; for assignment, see Table 2, and the “FLOAT” control type is selected during commissioning, a **second float** switch can additionally be connected to the terminals “PE”, “N”, “SW2” provided for this purpose on the short terminal block; see Figure 16. This second float switch operates purely as a high-water alarm without intervening in the cycle sequence; see Chapters 9.3.2.4 and 10.3.2.4.

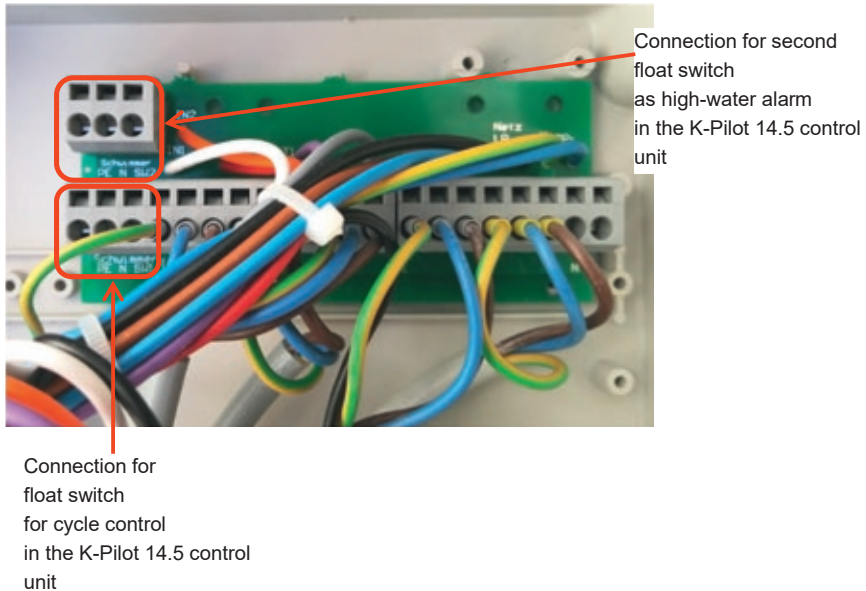

Figure 16: Connection of 2nd float switch as high-water alarm

6.4.7.4 Dual Float Switch

With the K-Pilot 14.5 control unit, it is possible to operate with a dual float switch. The float switch (S1) for the **“Dual Float” control type** is connected to the terminal “PE”, “N”, “SW1” provided for this purpose on the longer terminal block; for assignment, see Table 2; see Figure 17. The float switch (S2) is connected to the socket “PE”, “N”, “SW2” on the short terminal block; see Figure 17.

With this control unit setting, the two float switches are AND-linked, i.e. the control unit only switches ON when **both** float switches have floated up, and it only switches OFF when **both** float switches have dropped.

Float switch 2
at terminals "PE", "N", "SW2"

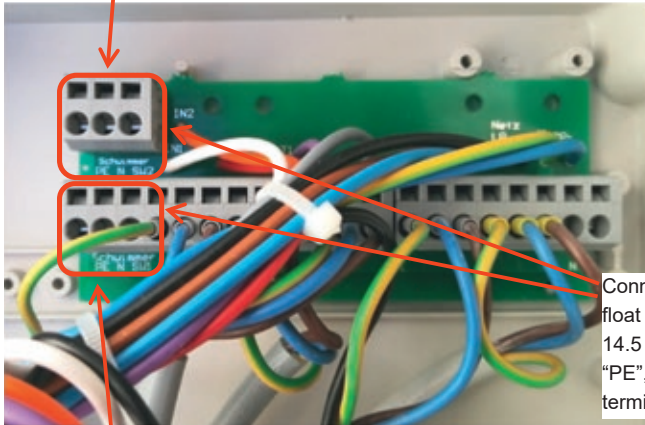

Connection for dual float switch in the K-Pilot 14.5 control unit at terminals "PE", "N", "SW1" and terminals "PE", "N", "SW2"

Float switch 1
at terminals "PE", "N", "SW1"

Figure 17: Connection of dual float switch on K-Pilot 14.5

6.4.7.5 Float BP

With the Float BP setting, the float switch intervenes in the SBR cycle in the following way: When the float switch floats up, feeding is ended. Clear water discharge is not ended when the float switch drops. However, an HW fault is reported if the float switch has not dropped after clear water discharge.

For this purpose, the float switch is connected to the terminals "PE", "N", "SW1"; see Figure 15, on the longer terminal block; for assignment, see Table 2, and the "FLOAT BP" control type is selected during commissioning.

This function is particularly useful for existing SBR plants that have a float switch with very small hysteresis installed.

6.4.8 Clear Water Pump

A **clear water pump** is used to overcome greater delivery heights. This then replaces the clear water airlift. A pump and an external float switch are used. The float switch is attached to the pump holder of the clear water pump.



Figure 18: Clear water pump with external float switch

The clear water pump is controlled via the cable for clear water. The “CW” cube connector on this connection is removed and the submersible motor pump is connected directly, or the cube connector is replaced by an earthed socket and the submersible motor pump is connected with an earthed plug.

The external float switch is connected to the control unit at the terminals “PE”, “N”, “SW1” provided for this purpose on the longer terminal block inside the housing; see Figure 15.

When operating with a clear water pump, the “Float” control type must be selected. For the required control unit setting, see Chapters 9.3.2.4 and 10.3.2.4.

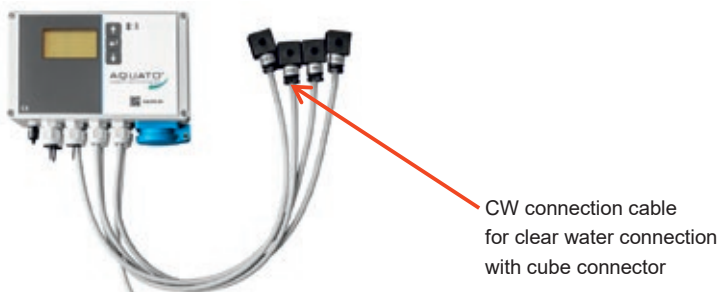

Figure 19: K-Pilot 14.5 control unit – clear water pump connection

7 Commissioning of the Plant

7.1 Before Commissioning



When constructing and operating wastewater plants, the relevant accident prevention regulations (UVV), guidelines, safety rules and information sheets of the responsible employers' liability insurance association (DGUV), as well as the regulations of the Association for Electrical, Electronic & Information Technologies (VDE), must be observed.

Before commissioning the plant, the installation and assembly of the plant components must have been completed as described in the **installation** and **operating manual**.

The volumes and design of the tanks must be dimensioned in accordance with the wastewater treatment and process engineering requirements. The pipework must be connected appropriately.

Care must be taken to ensure that ventilation via the roof is functioning. If this is not sufficient, a separate ventilation pipe must be installed. Forced ventilation may also be required, if necessary; this can be checked, for example, by means of a smoke test.

The watertightness test must be carried out before commissioning.

The technology must be properly installed in accordance with the wastewater treatment and process engineering requirements, and all required units must be connected to the control unit.



Before commissioning, the plant must be filled with water up to 5 cm above H_{Wmin} .



The electrical installation must have been carried out and completed by qualified specialist personnel. **If the housing of the control unit has been opened, it must be closed before commissioning.**



All required units, such as compressor, membrane aerators, airlifts, float switches, pumps, etc., must be connected to the control unit electrically and/or by hose to the respective inputs and outputs before commissioning.

7.2 Commissioning

After the required units have been connected, the plant is commissioned by inserting the mains plug of the control unit into the power supply. See Chapters 9.1, 10.1, 11.1 and 12.1.



Do not insert the mains plug of the control unit until the compressor and, if present, the air hose, float switch and submersible motor pump have been connected to the devices provided for this purpose on/in the control unit.



After the plug has been inserted, the control unit starts; see Chapters 9.1, 10.1, 11.1 and 12.1, with the message “booting system...”. The red LED then lights up briefly, followed by the green LED. At the same time, the start message “AQUATO” appears. The display Vx.xx.xx, e.g. V2.07.09, in the lower part of the message is the software version number.

During initial commissioning of the control unit, the following items, among others, must then be processed first; see Chapters 9.1 and 10.1: password, language, date and time, basic type, aeration, plant type with PE number, control type Time/Float, denitrification. Depending on the selection, further items may be added. The control unit then switches to manual operation so that the commissioning technician can test the functions individually.

After manual operation has ended, the control unit switches to the standard display. The device is now ready for operation. This is indicated by a flashing triangle ◀ in the lower right-hand corner of the LCD display. The plant now runs fully automatically.



The commissioning technician must ensure that the parameter settings in the control unit have been made in such a way that they comply with the requirements, e.g. basic type and discharge class, from the approval and the water-law permit for the plant in which the control unit is to be used.

8 Operation and Displays of the Control Unit

8.1 Operation

The control unit has a graphical LCD display with 128 x 64 pixels. The information is displayed in plain text and by means of two LEDs, one green and one red. Operation is carried out using three buttons.

Arrow key for selecting menu items



Middle button for confirming the input



Arrow key for selecting menu items



Figure 20: Operating buttons

The display remains switched on during the entire operation. A flashing triangle ◀ can be seen in the lower right-hand corner of the LCD display; it flashes once per second. When a unit, e.g. pump or compressor, is running, this is indicated by the green LED lighting up at the top right next to the display.

In the event of a fault, the red LED flashes and the buzzer sounds.

The standard LCD display shows the date and time in the top line and, below this, the current cycle phase in large letters, e.g. "AERATION". In the other menus, the name of the respective menu is shown at the very top, with the individual menu items below it. The change from one menu to another is made using the buttons . Pressing the middle button takes you into the respective menu. You can also move between the menu entries using the buttons .

The selected menu item is marked by a dark bar with inverse display. After selecting the line of the desired menu item, pressing the middle button takes you into the input mode of the respective submenu. Input mode can be recognized by a selected, inversely displayed line or digit. The options or digits can then be selected or changed using the buttons . The desired entry is confirmed by pressing the middle button .

If a multi-digit number entry is required, the highest digit is changed first using the buttons . The selection is confirmed with the middle button , and you then move to the next digit, and so on. If the input requires the selection of different options, e.g. YES / NO, the desired selection is also made using the buttons . When the desired option appears on the display, it is confirmed with the middle button.

You also return from the subitems to the main menu level using the buttons . If the marking bar is moved in one direction until it disappears from the menu, the next main menu opens.

8.2 Faults

Faults are indicated by the operating LED flashing red and by the buzzer sounding. On the display, errors are reported by being shown in the main menu alternately with the fault display. An example of an error message is shown in the following figures:

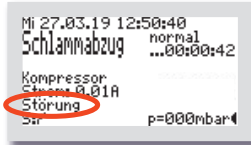
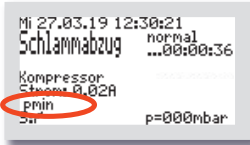

These three views alternate until the error is acknowledged.

An error message is acknowledged by pressing the button .

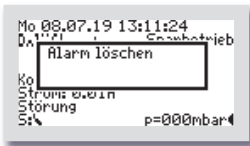

This switches off the buzzer and opens the “CLEAR ALARM” window. This is immediately followed by the prompt “ARE YOU SURE?”

This prompt can be answered by selecting either “NO” or “YES” in the lower line (“NEW”) using the buttons. If “NO” is selected, the error message remains active; only the acoustic warning signal is switched off.

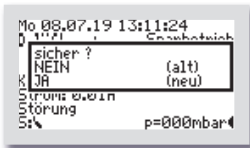

If “YES” is selected, the error display on the display is also cleared and the red flashing of the LED goes out.

The info window then opens with the details of the selected control unit setting. After approx. 3 seconds, the view changes back to the standard window.

The fault message on the display only goes out if the error has been eliminated and also reset on the control unit, as described above or in the “SETTINGS” menu.

The error message remains stored in the error logbook and can therefore also be evaluated later.

The possible faults/messages and information on troubleshooting can be found in Chapter 13.

8.3 Power Failure Alarm

The control unit has a battery-operated power failure alarm. In the event of a power failure, an alarm tone sequence is generated approximately every 30 seconds to alert the operator to the absence of the treatment function. A crossed-out socket is shown on the display, without backlighting. If the button  is pressed and held until an acknowledgement tone sounds, the alarm is permanently switched off. When the power supply returns after the power failure, the device switches on again automatically.

Note:



In a new device, the internal rechargeable batteries only reach their full capacity after a few days in order to achieve the maximum alarm duration. If the function of the internal rechargeable batteries decreases, they must be replaced with 2 NiMH rechargeable batteries, size AA.



The rechargeable batteries may only be replaced by a qualified electrician.

Disconnect the mains plug before opening the device.

The rechargeable batteries may only be disposed of properly.



According to the Battery Ordinance of the Federal Government (Federal Law Gazette 1998/II/20 of 02/04/1998), since 01/10/1998 all end users of batteries and rechargeable batteries have been obliged to return them to retailers or recycling/disposal facilities, e.g. municipal collection points. Disposal with household waste is expressly prohibited.

9 Operation as an SBR Plant

Operation of the small wastewater treatment plant must be carried out by the owner or by a competent person appointed by the owner, the operator.

After commissioning, the plant operates fully automatically. It is controlled by a PLC. The sequence and course of the phases are programmed in the control unit. The times for the aeration intervals, the denitrification phase, optional, as well as for feeding, discharge of the treated wastewater and return of the excess sludge are preset, but can be readjusted if required.

In the standard case, the cycles run purely time-controlled. However, it is possible to use a float switch and thereby additionally control the plant according to the water level.

If faults occur during operation of the plant, these are indicated visually and acoustically by the control unit. The LED flashes red and the buzzer sounds. The error message remains in the main display until the error is acknowledged; see Chapter 9.3.3.5.

The error message remains stored in the error logbook and can therefore also be evaluated later.

The control unit has a power failure alarm. In the event of a power failure, an alarm tone sequence is generated approximately every 30 seconds to alert the operator to the absence of the treatment function. When the power supply returns after the power failure, the device switches on again automatically.

9.1 Commissioning of the Control Unit



Before commissioning the plant, the primary treatment and biological treatment tanks must be filled with water up to 5 cm above H_{Wmin} , and the housing of the control unit must be closed if it has been opened. All required units must be connected to the control unit electrically and/or by hose.

Commissioning of the control unit begins by inserting the mains plug of the control unit. After the plug has been inserted, the control unit starts with a self-test lasting approx. 3 seconds, showing “booting system...” and the symbol of an hourglass . At the same time, the green LED lights up.

After the display “Fuse Check: values” with the message “Fuses o.k.”, the start message “AQUATO” appears on the display. The display Vx.xx.xx, e.g. V3.07.04, in the lower part of the message is the software version number.

During initial commissioning, the display “COMMISSIONING” then appears. During commissioning of the K-Pilot 14.5 control unit, the following must first be entered; see Chapters 9.3.2.4 as well as 9.3.3.1 and 9.3.3.6:

- Password, 4 digits, with password 1 or password 2 for extended options

- Language
- Date and time
- Basic plant type, here selection: "SBR"
- Valve for aeration YES / NO
- Plant size, e.g. "4 PE"
- Control type: "TIME", "FLOAT", "FLOAT BP" or "DUAL FLOAT"
- Denitrification YES / NO
- With pressure monitoring YES / NO

Only if password 2 was entered during password entry can the following additional options be selected during commissioning; see Chapter 9.3.2.4.

- Clear water discharge "AIRLIFT PUMP" / "MOTOR PUMP"

After these entries, the control unit automatically switches to manual operation; see Chapter 9.3.2.2. In manual operation, the different functions can be checked.

After manual operation has been ended, the control unit continues booting with the window "booting system..." and then "Fuse Check: values" with the message "Fuses o.k.", before the start message "AQUATO" appears with the display of the selected plant type. Automatic operation then starts automatically immediately afterwards.



The commissioning technician must ensure that the parameter settings in the control unit have been made in such a way that they comply with the requirements, e.g. basic type and discharge class, of the approval and the water-law permit for the plant in which the control unit is to be used.

Commissioning is then complete.

The automatic cycle runs through the following operating phases; these may vary depending on the exact setting:

- Excess sludge discharge
- Pressure monitoring
- Feeding
- Aeration
- Settling phase
- Clear water discharge

After these phases have been completed, the next cycle begins from the start.

9.2 Main Display

In the standard display, the control unit shows the switching status of the plant and the units, e.g.:



1st line: Date and time

2nd line: Current SBR phase, including “Feeding”, “Aeration”, “Settling Phase”, “Clear Water Discharge”, “Sludge Discharge”, “Pressure Monitoring” and, depending on the setting, further phases

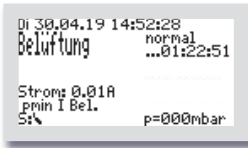

2nd line, right: Normal, energy-saving or holiday mode of the plant and, below this, in normal operation, the remaining time for which the current phase will continue; in energy-saving operation, the time elapsed since the start of the energy-saving phase

3rd line: Display of denitrification, only for discharge class D; otherwise blank line



4th line: Display of which unit is active; otherwise, if no unit is switched on, blank line

5th line: Operating current of the active unit, e.g. compressor, clear water pump if applicable, etc.

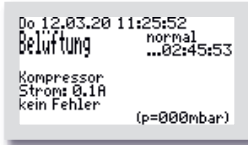

6th line: Error display; otherwise “NO ERROR” if no fault message is present

7th line: Float switch status up ρ / down \downarrow , only visible when float switch is activated; on the right, the currently present back pressure, shown in brackets if pressure monitoring has been switched off; on the far right, a triangle “◀” flashing once per second as operating status indication

If the button  is pressed in the standard display, an info window appears for approx. 3 seconds. The following is displayed in this window:

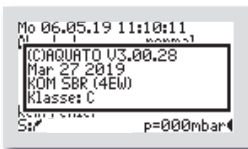

- Software version
- Date of the version
- Type: KOM SBR and set PE number
- Discharge class, special settings, e.g. CW pump or buffer

The exact display depends on the selected settings.

The button  can also be used in this menu to switch off the buzzer or the alarm. See also Chapter 9.3.3.5.

9.3 Menu

9.4 Menu Structure

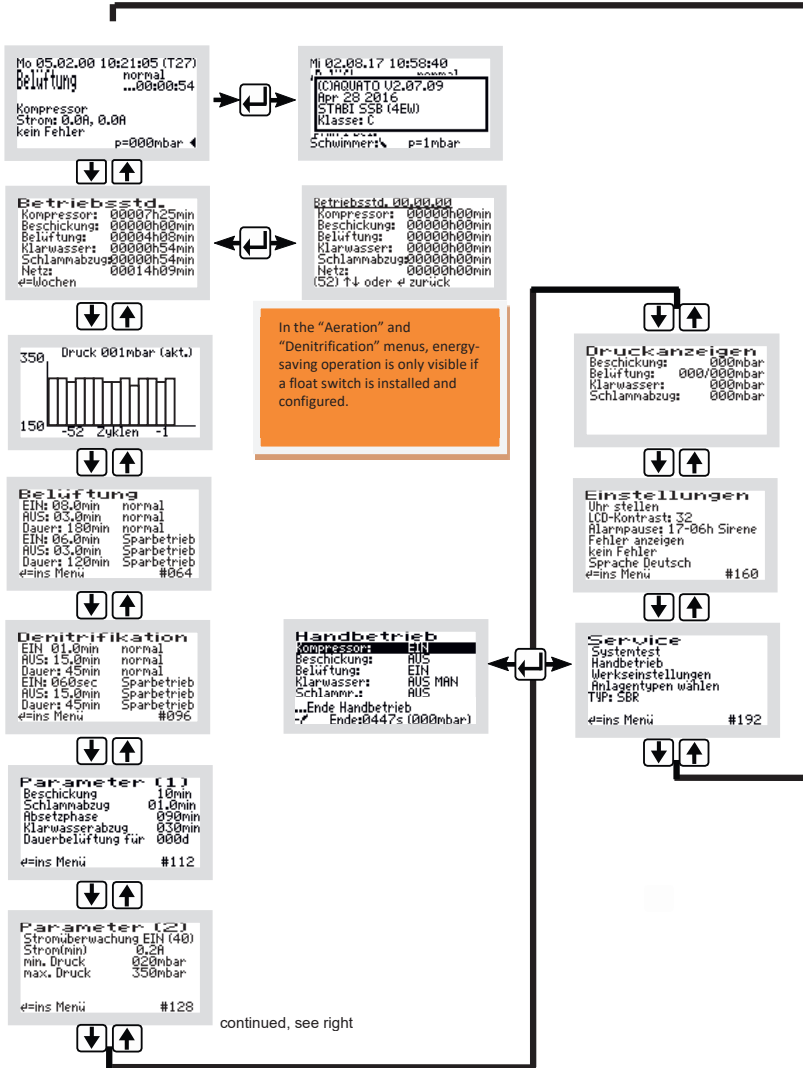









Figure 21: SBR menu structure

The exact display depends on the status of the plant and on the parameters that have been set. The different display variants are explained in more detail below.

You move from one menu to another using the arrow keys  . Bewegt man sich immer in die gleiche Richtung, gelangt man schließlich zur Standardanzeige zurück.

To access the submenus in the displayed menu, the middle button  must be pressed. After pressing the button , depending on the selected menu, either a window opens directly or the first menu item is marked by a black bar.

The individual items are selected using the arrow keys  . Pressing the button  takes you into the submenu or editing mode, if available.

9.4.1 “Service” Menu







The service menu is essentially intended for the service technician.

The following can be selected:

- System test / test operation
- Manual operation
- Factory settings, only with password 2
- Select plant types, only with password 1 or 2

9.4.1.1 System Test / Test Operation



In test operation, a check is carried out to determine whether the units are drawing current properly. If automatic test operation has been marked with the arrow keys   via the “SYSTEM TEST” menu item, it is called up with the middle button . The “System Test” window offers the selection “CANCEL” or “START TEST”. These two options are selected with the arrow keys   in the lower line “(NEW)”. After “START TEST” has been selected and confirmed, the system test begins.

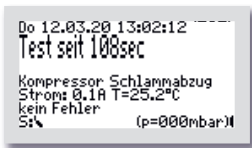

The test runs fully automatically. The individual functions are checked one after the other, each for approx. 15 seconds. If all units operate without errors, no alarm message appears.

Test operation can be cancelled by pressing the middle button .

After all functions have been checked, test operation ends automatically and the interrupted cycle is continued in automatic operation. If the settling phase was interrupted by the system test during the last 30 minutes of its runtime, the remaining runtime of the settling phase is automatically extended to 30 minutes following manual operation, in order to ensure that only the treated water can be pumped out of the plant.

9.4.1.2 Manual Operation

In manual operation of the K-Pilot 14.5 control unit, additional settings can be made in addition to the parameters that are always available: “Compressor”, “Feeding”, “Clear Water” and “Sludge Return”. The exact display depends on the parameters set during commissioning.



The Manual Operation menu consists of 2 windows. The arrow key can be used to select between the parameters “COMPRESSOR”, “CLEAR WATER” and “SLUDGE R” (= sludge return), which are always present, in the first window with the standard functions by moving the black bar to the desired entry.

If, for example, “COMPRESSOR” is selected, it can be switched “ON” and “OFF” with the middle button



At the bottom left, 2 float switch symbols with the current float switch position are visible.

If no float switch is connected, this corresponds to the symbol position down.



If a float switch is moved up and down, the display also changes accordingly.



Manual operation is ended by moving the marking bar to the menu item “... End Manual Operation” using the arrow keys and then confirming by pressing the middle button .

Manual operation is ended by moving the marking bar to the menu item “... End Manual Operation” using the arrow keys and then confirming by pressing the middle button . If manual operation is not ended with “... END MANUAL OPERATION”, the control unit automatically switches back to automatic operation 15 minutes after the last button was pressed.

After manual operation has been ended, the control unit continues the interrupted cycle in automatic operation. If the settling phase was interrupted by manual operation during the last 30 minutes of its runtime, the remaining runtime of the settling phase is automatically extended to 30 minutes following manual operation, in order to ensure that only the treated water can be pumped out of the plant.

9.4.1.3 Factory Settings

Under “FACTORY SETTINGS”, the limit for current faults can be changed. **Resetting the control unit**, which is also possible under Factory Settings, is **not permitted** during the entire operation. Access to the factory settings is **only possible with password 2**.

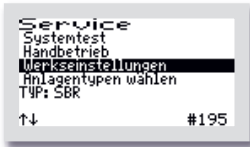



In the “FACTORY SETTINGS”, the following values can be changed/reset.



First enter password 1, or password 2 for more advanced settings, digit by digit and confirm each digit with the button  in order to access the menu.



The first window that opens is “MIN. CURRENT (mA)”. Here, the limit at which an error is displayed can be changed. The default setting is 200 mA. The lowest possible limit is 50 mA. The values can be changed digit by digit, starting on the left, in the lower line “(NEW)” using the buttons  . The selected value is accepted each time with the button . After confirming the 3rd digit, the next window opens automatically.

The deletion options that follow are not permitted during the entire operating life of a small wastewater treatment plant. The prompts must be answered with “NO”.



All prompts in the Factory Settings menu must be answered with “NO”. The data must not be deleted.





The window "CLEAR COUNTERS:" opens.

If "NO" is selected, the menus with the individual units are skipped and you go directly to the "CLEAR LOGBOOK" window.

→ **Answer: "NO"**



If "YES" is selected, the control unit switches to the individual units each time the button  is pressed. In the first following window, "COMPRESSOR", the counter for the compressor runtime can be reset to zero using the buttons   by setting "YES" in the lower line.

→ **Answer: "NO"**.



The same procedure can be followed in the windows that then appear: "FEEDING", "AERATION", "CLEAR WATER", "SLUDGE DISCHARGE", "MAINS", "UV", "DOSING TIME".

→ **Answer: "NO"**.



The last window to open in this menu is "CLEAR LOGBOOK". If "YES" is selected here, all entries and settings are deleted. The control unit then restarts with commissioning.

→ **Answer: "NO"**.



CAUTION! The processes "Clear counters:" and "Clear logbook" are prohibited during the entire operation of a plant, because the operating log must record the runtimes of the units.

9.4.1.4 Select Plant Type

In this menu, the plant type and plant size as well as further parameters required for operation can be set/changed.





Select the menu item “SELECT PLANT TYPES”.

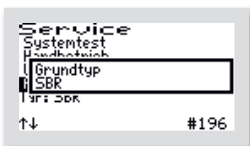

Then enter password 1, or password 2 for more advanced settings, digit by digit and confirm each digit with the button  in order to access the menu.







First, the “BASIC TYPE” of the plant is requested. Use the buttons   to select the desired type in the second line.

For operation as an SBR plant, select “SBR” and confirm with the button .

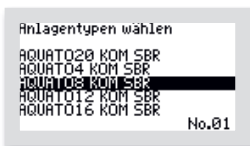

After selecting the basic type, the window “VALVE FOR AERATION” asks whether aeration is controlled with a valve. In the standard case, aeration is controlled without a valve. To select this setting, confirm the selection “NO” with the button .



Then, under “PLANT TYPE”, select the desired or required PE number using the buttons  . When the marking (= black bar) is on the correct PE number, according to the wastewater treatment calculation, confirm with the button . If the required PE number is not directly available for selection, select the next larger entry.

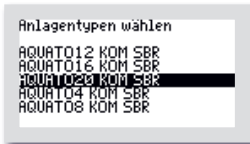

For plant sizes from 21 to 50 PE, please select “AQUATO from 20 KOM SBR”. The cycle default settings for plant sizes from 21 to 50 PE are the same; the different required air volumes are achieved by different sizes and quantities of membrane aerators and compressors. These settings can be readjusted if necessary.

All parameters for the treatment cycle are automatically preset by this selection, but can be readjusted if necessary.

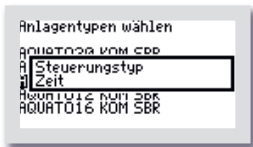

In the “CONTROL TYPE” window, you can choose between a time-controlled or float-controlled cycle. By pressing the buttons , you can select between “TIME”, “FLOAT”, “FLOAT BP” or “DUAL FLOAT”. The selected control type is accepted with the button . With the “TIME” setting, the sequence of the cycle is controlled only by time; with the float settings, it is additionally float-controlled; see Chapter 6.4.6.

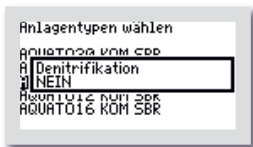
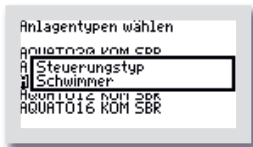

If “DENITRIFICATION” is desired/required, it can be switched on in the next window. The selection between “YES” and “NO” is made using the buttons . The selected status is accepted with the button . “YES” means that the plant runs with a denitrification phase; if “NO” is selected, this phase is switched off.

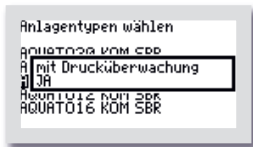

“PRESSURE MONITORING” can be switched on or off in the following window. The selection between “YES” and “NO” is made using the buttons . The selected status is accepted with the button .

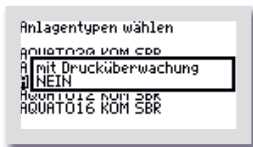



The selection “YES” means that the plant runs with pressure monitoring. For this purpose, a connection is required from the air hose between the compressor and air distribution to the hose connection for pressure measurement; see Chapter 6.3 Pressure Monitoring. If there is no such connection, pressure monitoring must be switched off by selecting “NO”.

If password 1 was used, the menu item “SELECT PLANT TYPES” is completed here and the software returns to the “SERVICE” main menu.

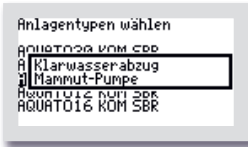

If the menu item “SELECT PLANT TYPES” was selected with password 2, additional setting options follow.

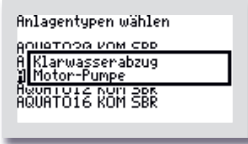

If a compressed-air lift is used for clear water discharge, please select “AIRLIFT PUMP” in the “CLEAR WATER DISCHARGE” window using the buttons  .



If clear water discharge is equipped with a submersible motor pump instead of the compressed-air lift, please select the option “MOTOR PUMP” in the “CLEAR WATER DISCHARGE” window. Confirm your selection with the button .

The menu item “SELECT PLANT TYPES” is now complete and the software returns to the “SERVICE” main menu. Use the buttons   to exit the menu.

9.4.2 “Settings” Menu





In the “SETTINGS” menu, the operator settings can be configured.



Press the button  to enter the menu and select the desired item.

9.4.2.1 Setting the Date and Time



To correct the time and/or date, select the line “SET CLOCK” using the buttons  . When the marking (= black bar) is on the desired entry, the window for adjusting the values is opened with the middle button .



The first digit can be changed using the buttons  . When the correct value has been set, the digit is accepted with the middle button . All following digits are selected in the same way.

Input sequence: 2 digits each:

Day, month, year, hour, minute (DD.MM.YY_hh.mm)

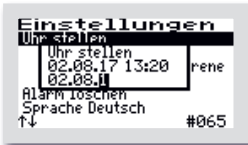

The clock is quartz-controlled. It should also be checked during maintenance. Care should be taken to ensure that the clock is set correctly, as this makes maintenance evaluation easier.

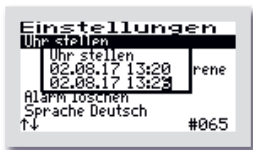

Example: Changing the time from 13:20 to 13:26.

9.4.2.2 LCD Contrast



The LCD contrast can be optimized here. As a rule, no change is necessary.

9.4.2.3 Alarm Buzzer (“Alarm Pause”)

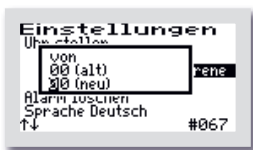

The acoustic alarm is switched off as standard from 5:00 p.m. to 6:00 a.m. During this time, errors are indicated visually only. This setting can be changed in the “ALARM PAUSE” menu item.



Caution:
No acoustic alarm is given during the time set here!



The sound for the alarm buzzer is set here. The selection options are: “SIREN”, “MELODY” and “OFF”.

The default setting is “SIREN”.

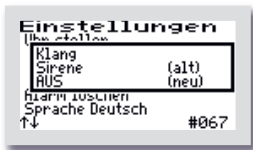

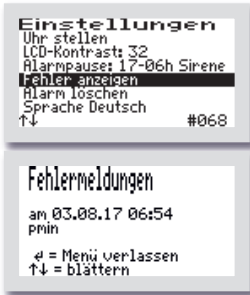

Caution:
With the “OFF” setting, no acoustic alarm is given!

9.4.2.4 Show Errors





The error logbook is called up via the menu item "SHOW ERRORS".

The error logbook shows the last 30 error events with date and time. The buttons   are used to scroll through the logbook, and the button  is used to exit the menu.

Nothing can be deleted in the error logbook!

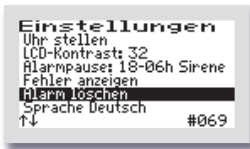
9.4.2.5 Clear Alarm



If a fault, an alarm, has occurred, the alarm message can be reset after marking the line "CLEAR ALARM" by pressing the button . A window with the message "OK" then opens for approx. 1 second, and the display in the menu then changes to "NO ERROR". The red flashing of the LED goes out and the error message is cleared in the standard window.

The error message remains stored in the error logbook and can therefore also be evaluated later.

Note: If, in the event of a fault, the button  is pressed in the main display, which is the standard display during operation, the buzzer is switched off and the "CLEAR ALARM" window opens; after a short time, this automatically changes to the prompt "ARE YOU SURE?".

If this is answered with "YES", the error display is cleared and the red flashing of the LED goes out. The error message remains stored in the error logbook and can therefore also be evaluated later.

If the prompt "ARE YOU SURE?" is answered with "NO", the error message remains in the main display.

The info window with the details of the plant setting then opens for approx. 3 seconds.

9.4.2.6 Language

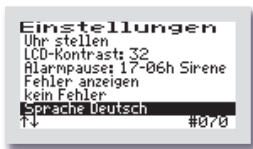

The language of the control unit is selected here. The password must be entered for this. The control unit is prepared for several languages. The languages currently programmed are:

- German
- English
- Swedish
- French
- Finnish

9.4.3 Further Menus with Displays or Settings



In the following menus, all current parameters of the plant can be displayed and, in some cases, set individually.

Adjustment may only be carried out by a qualified specialist, as otherwise the treatment performance of the plant may be reduced and the building authority approval may become invalid.

However, in order to change the displayed values, the password must first be entered.

To restore the original factory settings after changes have been made to the settings, e.g. changed aeration times, you can select the plant type again with the correct settings; see Chapter 9.3.2.4.

9.4.3.1 Operating Hours Display

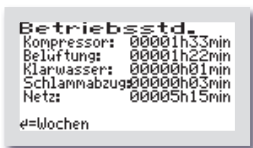

In the OPERATING HOURS menu, the operating hours of the respective units are displayed. The operating hours are counted up when the control unit has switched on the compressor, or the pump if applicable. The display is shown in hours and minutes.

If the button  is pressed, the operating hours of the last, up to 52, weeks are displayed, operating log.

The last line shows the week, for example week 52, in which the values were saved, always on Sunday.

The buttons   can be used to scroll from week to week.

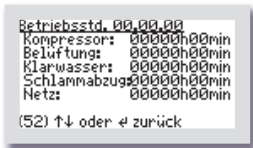

Note:

This function only works correctly if the date and time have been set correctly.

9.4.3.2 Pressure Logbook

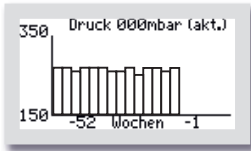

The "PRESSURE" graphics menu is only visible if pressure monitoring was selected during commissioning. In this menu, the current pressure is shown in the top line, and the back pressure from pressure monitoring is documented weekly in the graph.







The pressure is only shown graphically from 150 mbar upwards. When operating with a buffer, however, the display is only of limited significance.

9.4.3.3 Aeration



In the "AERATION" menu, the selected aeration intervals in normal operation are displayed, i.e. for how many minutes aeration is switched "ON" or "OFF" alternately, cycle timing.

The total duration of aeration, "DURATION:", is also displayed.

If required, the times can be changed individually. Press the button  to enter the menu. The line to be changed is selected using the buttons  . The menu item is called up with the button . The settings are changed using the buttons   and confirmed with the button .



The aeration interval is also displayed for energy-saving operation, i.e. for how many minutes aeration is switched ON or OFF.

The total duration of aeration in energy-saving operation, "DURATION: XXXmin ENERGY-SAVING OPERATION", is also displayed.



Note:

The "ENERGY-SAVING OPERATION" displays at the bottom of the AERATION window are only visible if the "FLOAT" CONTROL TYPE is set.

Energy-saving operation begins with the aeration phase if the float switch has not floated up during the feeding phase, and runs for three days. If the float switch does not float up again during this time, the plant switches to holiday mode. The aeration times for this cannot be set. They are automatically set to one third of the set energy-saving operation time. As soon as the float switch floats up again during the feeding phase, energy-saving or holiday mode is cancelled and the plant changes to normal operation. This begins with the aeration phase.

9.4.3.4 Denitrification









Note:

This menu is only visible if denitrification is activated.

This menu is only visible if denitrification is activated.

In the “DENITRIFICATION” menu, the selected aeration intervals in normal operation are displayed, i.e. for how many minutes aeration is switched “ON” or “OFF” alternately, cycle timing.

The total duration of aeration, “DURATION:”, is also displayed. If required, the times can be changed individually.

Press the button  to enter the menu. The line to be changed is selected using the buttons  . The menu item is called up with the button . The settings are changed using the buttons   and confirmed with the button .

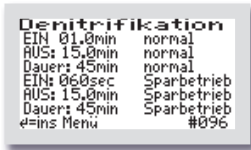

Note:

The “ENERGY-SAVING OPERATION” display in the “DENITRIFICATION” menu is only visible if the “FLOAT” CONTROL TYPE is set.

The aeration interval is also displayed for energy-saving operation, i.e. for how many minutes aeration is switched “ON” or “OFF”.

The total duration of aeration in energy-saving operation, “DURATION: XXXmin ENERGY-SAVING OPERATION”, is also displayed.

9.4.3.5 Parameter 1

In the "PARAMETER 1" menu, different parameters are displayed depending on the setting. The parameters "FEEDING", "SLUDGE DISCHARGE", "SETTLING PHASE" and "CLEAR WATER DISCHARGE" are always present.

```

Parameter (1)
Beschickung      10min
Schlammabzug    01.0min
Absetzphase     090min
Klarwasserabzug 030min
Dauerbelüftung für 000d
←ins Menü      #112
  
```

In this menu, depending on the setting, the duration of the following cycle phases is displayed:

- FEEDING
- SLUDGE DISCHARGE
- SETTLING PHASE
- CLEAR WATER DISCHARGE
- CONTINUOUS AERATION FOR XXX D

If required, the times can be changed individually.

In addition, continuous aeration during the start-up phase is possible with the menu item "CONTINUOUS AERATION FOR XXX D". With this setting, aeration can be used in continuous operation for a specified number of days. During this time, aeration is continuous throughout the aeration phase.

```

Parameter (1)
Beschickung      10min
Schlammabzug    01.0min
Absetzphase     090min
Klarwasserabzug 030min
Dauerbelüftung für 030d
←ins Menü      #112
  
```

In the "Parameter 1" menu, when password 2 is entered, the connected float switch(es) are displayed in the bottom line with the set waiting time until the warning.

In the example, the float switch message becomes active after 30 days without a switching operation of the float switch.

```

Parameter (1)
Beschickung      10min
Schlammabzug    01.0min
Absetzphase     090min
Klarwasserabzug 030min
Dauerbelüftung für 000d
↑↓              #117
  
```

In the bottom line, the waiting times until the warning can be adjusted by entering password 2.

```

Parameter (1)
Beschickung      10min
Schlammabzug    01.0min
Absetzphase     090min
Klarwasserabzug 030min
Dauerbelüftung für 010d
←ins Menü      #112
  
```

If 0 days is entered, the float switch message is switched off.

In the example, the float switch message for the float switch becomes active after 10 days without a switching operation of the float switch.

9.4.3.6 Parameter 2

In the “PARAMETER 2” menu, different parameters are displayed depending on the setting. The parameters “CURRENT MONITORING” and “MIN. CURRENT” are always present.

When the control unit switches on a unit, e.g. the compressor or a pump, it cannot be guaranteed with certainty that this unit is actually running. Overheating, defective cables or other defects may mean that the switching relay is switched on, but the unit is nevertheless not running. The control unit therefore monitors whether a current is also flowing in the circuit. If the current falls below a limit value, which is set by default in the software to 0.2 A, a current alarm is displayed, e.g. “I Aer”.

If pressure monitoring is switched on, the control unit also monitors the pressure generated during feeding, aeration, sludge return and clear water discharge. The minimum pressure is set by default to 20 mbar and the maximum pressure to 350 mbar. If the pressure falls below the minimum permissible pressure or exceeds the maximum permissible pressure, the control unit triggers an alarm, “p min” or “p max”.



In this menu, current monitoring can be switched “OFF” or “ON”. In the standard case, current monitoring is set to “ON”.

In addition, the currently flowing current is shown in the main display for monitoring purposes.



If required, the minimum and maximum permissible pressure can be changed in this menu.

If pressure monitoring is switched off, the displays “min. pressure” and “max. pressure” are omitted.

9.4.3.7 Pressure Displays



The "PRESSURE DISPLAYS" menu is only visible if pressure monitoring was selected during commissioning. In this menu, the respective pressure during the last cycle is displayed. The back pressure for feeding, clear water and excess sludge is stored during each individual process. Only the pressure measurement of the respective last phase is displayed.

For aeration, 2 values are displayed: the minimum and the maximum pressure.

If pressure monitoring is switched off, this menu is omitted.

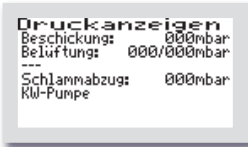

If a clear water pump is connected instead of the clear water airlift, this is shown below the actual pressure displays as the text "CW PUMP". In addition, this output is not displayed as a pressure output.

In the example, a clear water pump is connected.

9.5 Default Settings

PE number	8
Control type:	Time
Denitrification:	No

9.6 Switching Times – Basic Settings

PE number	Aeration Normal Operation			Aeration energy-saving operation			Denitrification normal operation			Denitrification energy-saving operation			Settling phase (min)	Clear water discharge (min)	Sludge discharge (min)	Feeding (min)
	Aerators ON (min)	Aerators OFF (min)	Duration (min)	Aerators ON (min)	Aerators OFF (min)	Duration (min)	Aerators ON (min)	Aerators OFF (min)	Duration (min)	Aerators ON (min)	Aerators OFF (min)	Duration (min)				
4	3,0	5,0	180	2,0	5,0	120	1,0	15,0	45	1,0	15,0	45	90	5	1,0	5
8	5,0	5,0	180	3,0	5,0	120	1,0	15,0	45	1,0	15,0	45	90	10	1,0	10
12	7,0	3,0	180	5,0	5,0	120	1,0	15,0	45	1,0	15,0	45	90	15	2,0	15
16	7,0	3,0	180	5,0	5,0	120	1,0	15,0	45	1,0	15,0	45	90	15	2,0	15
20	8,0	3,0	180	6,0	3,0	120	1,0	15,0	45	1,0	15,0	45	90	20	2,0	20
>20	8,0	3,0	180	6,0	3,0	120	1,0	15,0	45	1,0	15,0	45	90	20	2,0	20

The plant only switches to energy-saving and holiday mode if a float switch is installed and the "FLOAT" control type setting is selected. Energy-saving operation is switched on if the float switch has not floated up after sludge discharge. Holiday mode begins after energy-saving operation if the float switch has not floated up within 3 days of energy-saving operation. In holiday mode, the aeration time is reduced again by 2/3. As soon as the float switch floats up again, the plant switches back to normal operation. With the "FLOAT" control type setting, all clear water discharge times are preset to 30 minutes.

10 Operation as a Fluidized-Bed or Fixed-Bed Plant

Operation of the small wastewater treatment plant must be carried out by the owner or by a competent person appointed by the owner, the operator.

After commissioning, the plant operates fully automatically. It is controlled by a PLC. The sequence and course of the phases are programmed in the control unit. The times for the aeration intervals and for the return of the excess sludge are preset, but can be readjusted if required.

In the standard case, the cycles run purely time-controlled. However, it is possible to use a float switch as a high-water alarm.

If faults occur during operation of the plant, these are indicated visually and acoustically by the control unit. The red LED flashes and the buzzer sounds. The error message remains in the main display until the error is acknowledged; see Chapter 10.3.3.5.

The error message remains stored in the error logbook and can therefore also be evaluated later.

The control unit has a power failure alarm. In the event of a power failure, an alarm tone sequence is generated approximately every 30 seconds to alert the operator to the absence of the treatment function. When the power supply returns after the power failure, the device switches on again automatically.

10.1 Commissioning of the Control Unit



Before commissioning the plant, the primary treatment and biological treatment tanks must be filled with water up to the outlet, and the housing of the control unit must be closed if it has been opened. All required units must be connected to the control unit electrically and/or by hose.

Commissioning of the control unit begins by inserting the mains plug of the control unit. After the plug has been inserted, the control unit starts with a self-test lasting approx. 3 seconds, showing “booting system...” and the symbol of an hourglass . At the same time, the green LED lights up.

After the display “Fuse Check: values” with the message “Fuses o.k.”, the start message “AQUATO” appears on the display. The display Vx.xx.xx, e.g. V3.07.04, in the lower part of the message is the software version number.

During initial commissioning, the display “COMMISSIONING” then appears. During commissioning of the K-Pilot 14.5 control unit, the following must first be entered; see Chapters 10.3.2.4 as well as 10.3.3.1 and 10.3.3.6:

- Password, 4 digits, with password 1
or with password 2 for extended options
- Language
- Date and time
- Basic plant type, here selection: “**FLUIDIZED BED**” or “**FIXED BED**”
- Plant size, e.g. “4 PE”
- With pressure monitoring YES / NO

Only if password 2 was entered during password entry can the following additional options be selected during commissioning; see Chapter 10.3.2.4.

- Sludge discharge airlift pump / motor pump

After these entries, the control unit automatically switches to manual operation; see Chapter 10.3.2.2. In manual operation, the different functions can be checked.

After manual operation has been ended, the control unit continues booting with the window “booting system...” and then “Fuse Check: values” with the message “Fuses o.k.,” before the start message “AQUATO” appears with the display of the selected plant type. Automatic operation then starts automatically immediately afterwards.



The commissioning technician must ensure that the parameter settings in the control unit have been made in such a way that they comply with the requirements, e.g. basic type and discharge class, from the approval and the water-law permit for the plant in which the control unit is to be used.

Commissioning is then complete.

The automatic cycle runs through the following operating phases; these may vary depending on the exact setting:

- Aeration
- Excess sludge discharge

After these phases have been completed, the next cycle begins from the start.

10.2 Main Display

In the standard display, the control unit shows the switching status of the plant and the units, e.g.:

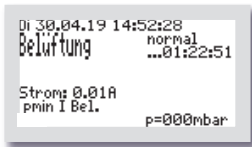
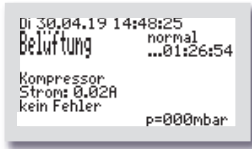

- 1st line: Date and time
- 2nd line: Current phase: "Aeration", "Sludge Discharge" and, depending on the setting, further phases
- 2nd line, right: Normal or energy-saving operation of the plant and, below this, in normal operation, the remaining time for which the current phase will continue; in energy-saving operation, the time elapsed since the start of the energy-saving phase
- 3rd line: Display of denitrification, only for discharge class D; otherwise blank line
- 4th line: Display of which unit is active; otherwise, if no unit is switched on, blank line
- 5th line: Operating current of the active unit, e.g. compressor, clear water pump if applicable, etc.
- 6th line: Error display; otherwise "NO ERROR" if no fault message is present
- 7th line: Float switch status up ρ / down \downarrow , only visible when float switch is activated; on the right, the currently present back pressure, shown in brackets if pressure monitoring has been switched off; on the far right, a triangle „◀" flashing once per second as operating status indication

If the button  is pressed in the standard display, an info window appears for approx. 3 seconds. The following is displayed in this window:

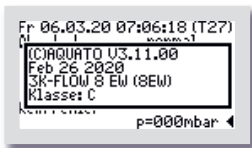

- Software version
- Date of the version
- Type 3K-FLOW or 3K-PLUS and set PE number
- Discharge class, special settings, e.g. ESS pump

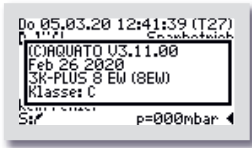

The exact display depends on the selected settings.

The button  can also be used in this menu to switch off the buzzer or the alarm. See also Chapter 10.3.3.5.

10.3 Menu

10.3.1 Menu Structure

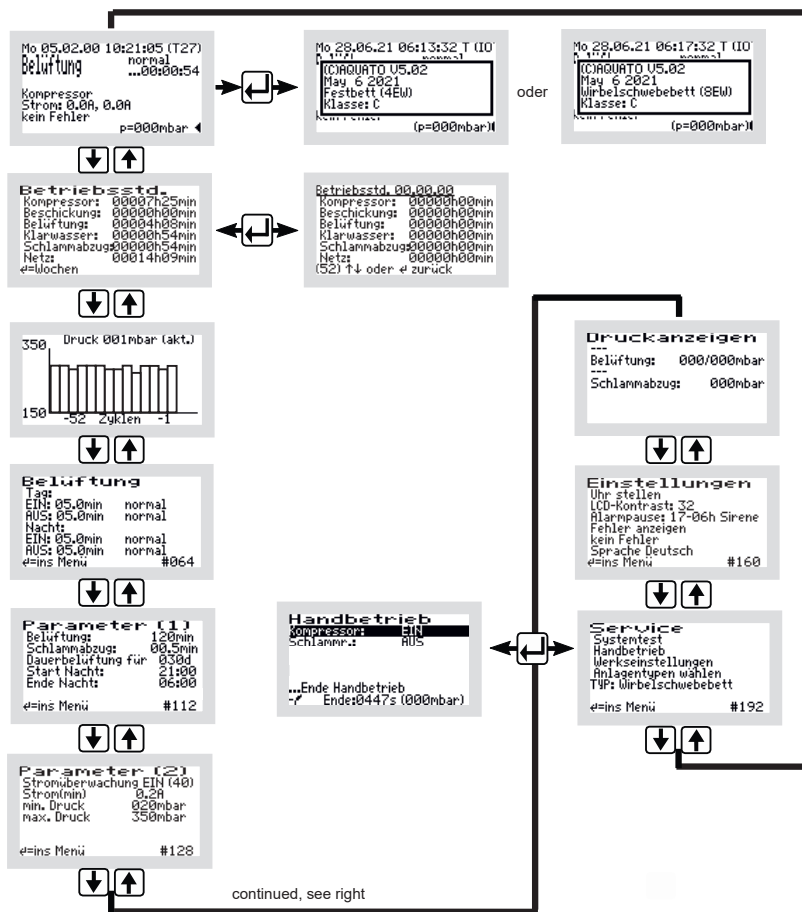





Figure 22: Menu structure for fluidized-bed or fixed-bed plant

The exact display depends on the status of the plant and on the parameters that have been set. The different display variants are explained in more detail below.

You move from one menu to another using the arrow   keys. If you keep moving in the same direction, you will eventually return to the standard display.

To access the submenus in the displayed menu, the middle  button must be pressed. After pressing the button , depending on the selected menu, either a window opens directly or the first menu item is marked by a black bar.

The individual items are selected using the   arrow keys. Pressing the button  takes you into the submenu or editing mode, if available.

10.3.2 “Service” Menu







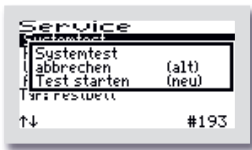

The service menu is essentially intended for the service technician.

The following can be selected:

- System test / test operation
- Manual operation
- Factory settings, only with password 2
- Select plant types, only with password 1 or 2

10.3.2.1 System Test / Test Operation



In test operation, a check is carried out to determine whether the units are drawing current properly. If automatic test operation has been marked with the   arrow keys via the “SYSTEM TEST” menu item, it is called up with the  button. The “System Test” window offers the selection “CANCEL” or “START TEST”. These two options are selected with the   arrow keys in the lower line “(NEW)”. After “START TEST” has been selected and confirmed, the system test begins.

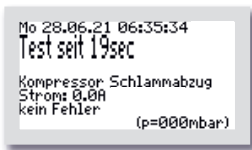

The test runs fully automatically. The individual functions are checked one after the other, each for approx. 15 seconds. If all units operate without errors, no alarm message appears.



Test operation can be cancelled by pressing the  button.

After all functions have been checked, test operation ends automatically and the interrupted cycle is continued in automatic operation. If the settling phase was interrupted by the system test during the last 30 minutes of its runtime, the remaining runtime of the settling phase is automatically extended to 30 minutes following manual operation, in order to ensure that only the treated water can be pumped out of the plant.

10.3.2.2 Manual Operation



In manual operation of the K-Pilot 14.5 control unit, additional settings can be made in addition to the parameters that are always available: “Compressor” and “Sludge R.” (= sludge return). The exact display depends on the parameters set during commissioning.



The buttons   can be used to select between the parameters “COMPRESSOR” and “SLUDGE R.” (= sludge return), which are always present, as well as further menu items that differ depending on the default setting, by moving the black bar to the desired entry.



If “COMPRESSOR” is selected, it can be switched “ON” and “OFF” with the button .

Manual operation is ended by moving the marking bar to the menu item “... End Manual Operation” using the buttons   and then confirming by pressing the button . If manual operation is not ended with “... END MANUAL OPERATION”, the control unit automatically switches back to automatic operation 15 minutes after the last button was pressed.

After manual operation has been ended, the control unit continues the interrupted cycle in automatic operation.

10.3.2.3 Factory Settings

Under “FACTORY SETTINGS”, the limit for current faults can be changed. **Resetting the control unit**, which is also possible under Factory Settings, is **not permitted** during the entire operation. Access to the factory settings is **only possible with password 2**.

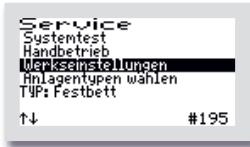

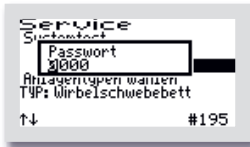

In the “FACTORY SETTINGS”, the following values can be changed/reset..



First enter password 1, or password 2 for more advanced settings, digit by digit and confirm each digit with the button  in order to access the menu.



The first window that opens is “MIN. CURRENT (mA)”. Here, the limit at which an error is displayed can be changed. The default setting is 200 mA. The lowest possible limit is 50 mA. The values can be changed digit by digit, starting on the left, in the lower line “(NEW)” using the buttons  . The selected value is accepted each time with the button . After confirming the 3rd digit, the next window opens automatically.

The deletion options that follow are not permitted during the entire operating life of a small wastewater treatment plant. The prompts must be answered with “NO”.



**All prompts in the Factory Settings menu must be answered with “NO”.
The data must not be deleted.**





The window "CLEAR COUNTERS:" opens.

If "NO" is selected, the menus with the individual units are skipped and you go directly to the "CLEAR LOGBOOK" window.

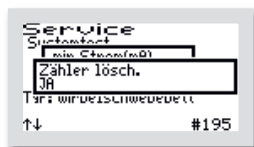
→ Answer: "NO".



If "YES" is selected, the control unit switches to the individual units each time the  button is pressed. In the first following window, "COMPRESSOR", the counter for the compressor runtime can be reset to zero using the   buttons by setting "YES" in the lower line.

→ Answer: "NO".



The same procedure can be followed in the windows that then appear: "FEEDING", "AERATION", "CLEAR WATER", "SLUDGE DISCHARGE", "MAINS", "DOSING TIME", "UV".

→ Answer: "NO".

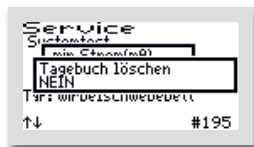

The last window to open in this menu is "CLEAR LOGBOOK". If "YES" is selected here, all entries and settings are deleted. The control unit then restarts with commissioning.

→ Answer: "NO".



CAUTION! The "Clear counters" and "Clear logbook" processes must **not be carried out** during the entire operation of a plant, because the operating log must record the runtimes of the units.

10.3.2.4 Select Plant Type

In this menu, the plant type and plant size as well as further parameters required for operation can be set/changed.





Select the menu item “SELECT PLANT TYPES”.





Then enter password 1, or password 2 for more advanced settings, digit by digit and confirm each digit with the button  in order to access the menu.



First, the “BASIC TYPE” of the plant is requested. Use the   buttons to select the desired type in the second line.

For operation as a fixed-bed plant, select “**FIXED BED**”; for operation as a fluidized-bed plant, select “**FLUIDIZED BED**”. Confirm your selection with the button .



Then, under “PLANT TYPE”, select the desired or required PE number using the   buttons. When the marking (= black bar) is on the correct PE number, according to the wastewater treatment calculation, confirm with the  button. If the required PE number is not directly available for selection, select the next larger entry.

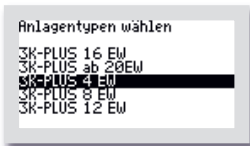

All parameters for the treatment cycle are automatically preset by this selection, but can be readjusted if necessary.

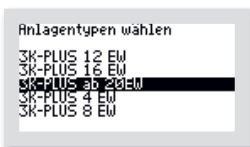

For plant sizes from 21 to 50 PE, please select “3K-FLOW from 20” or “3K-PLUS from 20”. The cycle default settings for plant sizes from 21 to 50 PE are the same; the different required air volumes are achieved by different sizes and quantities of membrane aerators and compressors. These settings can be readjusted if necessary.

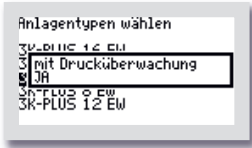

The pressure monitoring can then be switched “ON” or “OFF” in the “WITH PRESSURE MONITORING” window.



To use this monitoring function, the pressure sensor must be connected to the air hose between the compressor and the aerators.

If the sensor is not connected to the air hose, “NO” must be selected.



If password 1 was used, the menu item “SELECT PLANT TYPES” is completed here and the software returns to the “SERVICE” main menu. Use the   buttons to exit the menu.

If the menu item “SELECT PLANT TYPES” was selected with password 2, the additional functions follow as further setting options.

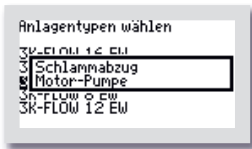

Additional functions can only be commissioned with **password 2**.



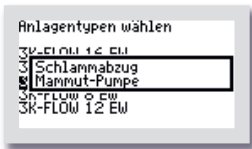

The next prompt asks how sludge discharge is to take place, with a submersible motor pump or with a compressed-air lift. If sludge return is to be carried out with a pump instead of an airlift, please select the option “MOTOR PUMP” in the following “SLUDGE DISCHARGE” window using the   buttons.



If you do not require this option, please answer the prompt with “AIRLIFT PUMP”.

Confirm your selection with the  button.

The menu item “SELECT PLANT TYPES” is now complete and the software returns to the “SERVICE” main menu. Use the   buttons to exit the menu.



10.3.3 “Settings” Menu



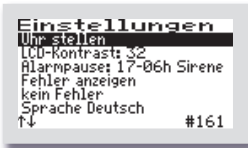

In the “SETTINGS” menu, the operator settings can be configured. Press the  button to enter the menu and select the desired item.

10.3.3.1 Setting the Date and Time



To correct the time and/or date, select the line “SET CLOCK” using the   buttons. When the marking (= black bar) is on the desired entry, the window for adjusting the values is opened with the middle  button.



The first digit can be changed using the   buttons. When the correct value has been set, the digit is accepted with the middle  button. All following digits are selected in the same way.



Input sequence: 2 digits each:

Day, month, year, hour, minute (DD.MM.YY_hh.mm)



The clock is quartz-controlled. It should also be checked during maintenance. Care should be taken to ensure that the clock is set correctly, as this makes maintenance evaluation easier.

Example: Changing the time from 13:20 to 13:26.

10.3.3.2 LCD Contrast



The LCD contrast can be optimized here. As a rule, no change is necessary.

10.3.3.3 Alarm Buzzer (“Alarm Pause”)

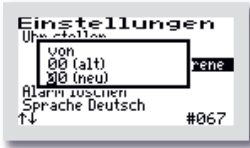

The acoustic alarm is switched off as standard from 5:00 p.m. to 6:00 a.m. During this time, errors are indicated visually only. This setting can be changed in the “ALARM PAUSE” menu item.



Caution:

No acoustic alarm is given during the period set here!



The sound for the alarm buzzer is set here. The selection options are: “SIREN”, “MELODY” and “OFF”.

The default setting is “SIREN”.

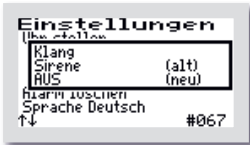

Caution:



With the “OFF” setting, no acoustic alarm is given!

10.3.3.4 Show Errors



The error logbook is called up via the menu item “SHOW ERRORS”.





The error logbook shows the last 30 error events with date and time. The   buttons are used to scroll through the logbook, and the  button is used to exit the menu.

Nothing can be deleted in the error logbook!

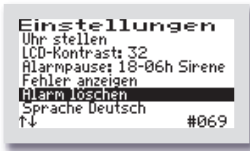
10.3.3.5 Clear Alarm



If a fault, an alarm, has occurred, the alarm message can be reset after marking the line “CLEAR ALARM” by pressing the  button. A window with the message “OK” then opens for approx. 1 second, and the display in the menu then changes to “NO ERROR”. The red flashing of the LED goes out and the error message is cleared in the standard window. The error message remains stored in the error logbook and can therefore also be evaluated later.

Note: If, in the event of a fault, the  button is pressed in the main display, which is the standard display during operation, the buzzer is switched off and the “CLEAR ALARM” window opens; after a short time, this automatically changes to the prompt “ARE YOU SURE?”.

If this is answered with “YES”, the error display is cleared and the red flashing of the LED goes out. The error message remains stored in the error logbook and can therefore also be evaluated later.

If the prompt “ARE YOU SURE?” is answered with “NO”, the error message remains in the main display.

The info window with the details of the plant setting then opens for approx. 3 seconds.

10.3.3.6 Language

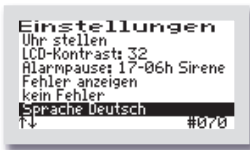

The language of the control unit is selected here. The password must be entered for this. The control unit is prepared for several languages. The languages currently programmed are:

- German
- English
- Swedish
- French
- Finnish

10.3.4 Further Menus with Displays or Settings



In the following menus, all current parameters of the plant can be displayed and, in some cases, set individually. Adjustment may only be carried out by a qualified specialist, as otherwise the treatment performance of the plant may be reduced and the building authority approval may become invalid.

However, in order to change the displayed values, the password must first be entered.

To restore the original factory settings after changes have been made to the settings, e.g. changed aeration times, you can select the plant type again; see Chapter 10.3.2.4. The default values will then be set again.

10.3.4.1 Operating Hours Display

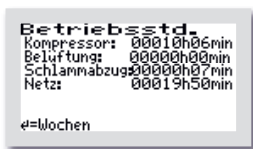

In the “OPERATING HOURS” menu, the operating hours of the respective units are displayed. The operating hours are counted up when the control unit has switched on the compressor, or a pump if applicable. The display is shown in hours and minutes.

If the  button is pressed, the operating hours of the last, up to 52, weeks are displayed, operating log.



The last line shows the week, for example week 1, in which the values were saved, always on Sunday.

The   buttons can be used to scroll from week to week.



Note:

This function only works correctly if the date and time have been set correctly.

10.3.4.2 Pressure Logbook

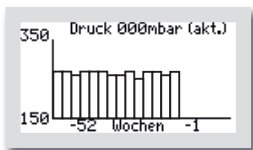







The “PRESSURE” graphics menu is only visible if pressure monitoring was selected during commissioning. In this menu, the current pressure is shown in the top line, and the back pressure from pressure monitoring is documented weekly in the graph.

The pressure is only shown graphically from 150 mbar upwards.

10.3.4.3 Aeration









In the "AERATION" menu, the selected aeration intervals in day and night operation are displayed, i.e. it is shown for how many minutes aeration is switched "ON" or "OFF" alternately, cycle timing.

If required, the times can be changed individually. Press the  button to enter the menu. The line to be changed is selected using the   buttons. The menu item is called up with the  button. The settings are changed using the   buttons and confirmed with the  button.

10.3.4.4 Parameter 1



In this menu, the duration of the total aeration phase and of sludge discharge is displayed, as well as the start and end of night operation and, depending on the setting, further parameters.

If required, the times can be changed individually. Press the  button to enter the menu. The line to be changed is selected using the   buttons. The menu item is called up with the  button. The settings are changed using the   buttons and confirmed with the  button.

10.3.4.5 Parameter 2

In the "PARAMETER 2" menu, different parameters are displayed depending on the setting. The parameters "CURRENT MONITORING" and "MIN. CURRENT" are always present.

When the control unit switches on a unit, e.g. the compressor or a pump, it cannot be guaranteed with certainty that this unit is actually running. Overheating, defective cables or other defects may mean that the switching relay is switched on, but the unit is nevertheless not running. The control unit therefore monitors whether current is also flowing in the circuit. If the current falls below a limit value, which is set by default in the software to 0.2 A, a current alarm is displayed, e.g. "I Aer".

If pressure monitoring is switched on, the control unit also monitors the pressure generated during aeration and sludge return. The minimum pressure is set by default to 20 mbar and the maximum pressure to 350 mbar. If the pressure falls below the minimum permissible pressure or exceeds the maximum permissible pressure, the control unit triggers an alarm, "p min" or "p max".



In this menu, current monitoring can be switched “OFF” or “ON”. In the standard case, current monitoring is set to “ON”.

In addition, the currently flowing current is shown in the main display for monitoring purposes.



If required, the minimum and maximum permissible pressure can be changed in this menu.

If pressure monitoring is switched off, the displays “min. pressure” and “max. pressure” are omitted.

10.3.4.6 Pressure Displays



The “PRESSURE DISPLAYS” menu is only visible if pressure monitoring was selected during commissioning. In this menu, the respective pressure during the last cycle is displayed. The back pressure for aeration and excess sludge is stored during each individual process. Only the pressure measurement of the respective last phase is displayed.

For aeration, 2 values are displayed in each case: the minimum and the maximum pressure.

If pressure monitoring is switched off, this menu is omitted.



If a sludge pump is connected instead of the airlift, this output is not displayed as a pressure output.

10.4 Default Settings

PE number: 8
Control type: Float

10.5 Switching Times – Basic Settings

Aeration phase day operation		Aeration phase night operation		PE number	Aeration phase day operation			Aeration phase night operation			Schlammabzug (sec)
Start of day operation (time)	End of day operation (time)	Start of night operation (time)	End of night operation (time)		Aerators ON (min)	Aerators OFF (min)	Duration (min)	Aerators ON (min)	Aerators OFF (min)	Duration (min)	
6:00	21:00	21:00	6:00	4	5,0	5,0	60	5,0	10,0	60	30
6:00	21:00	21:00	6:00	8	5,0	5,0	60	5,0	5,0	60	30
6:00	21:00	21:00	6:00	12	10,0	5,0	60	10,0	5,0	60	30
6:00	21:00	21:00	6:00	16	10,0	5,0	60	10,0	5,0	60	30
6:00	21:00	21:00	6:00	20	10,0	5,0	60	10,0	5,0	60	30
6:00	21:00	21:00	6:00	>20	10,0	5,0	60	10,0	5,0	60	30

11 Operation as a Trickling Filter Plant

Operation of the small wastewater treatment plant must be carried out by the owner or by a competent person appointed by the owner, the operator.

After commissioning, the plant operates fully automatically. It is controlled by a PLC. The sequence and course of the phases are programmed in the control unit. The times adapted to the plant for pumping out the clear water and feeding the trickling filter and the primary treatment from the pump sump, as well as for returning the excess sludge from the final clarification, must be set in the control unit.

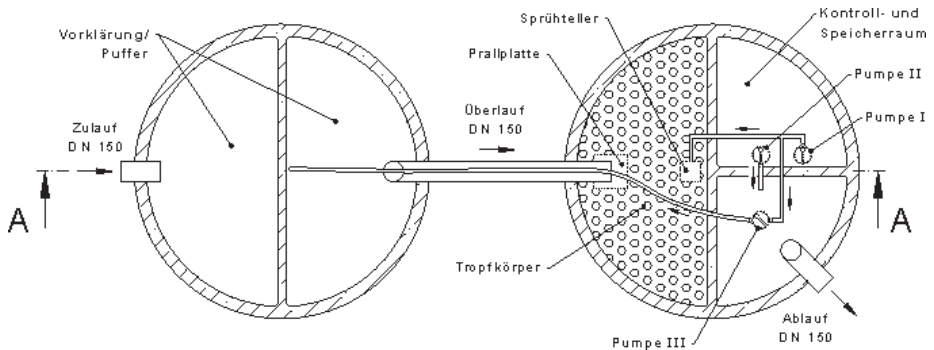

Figure 23: Trickling filter plant with pumps

Operation as a trickling filter plant can take place in 3 different configurations:

A) Units of the trickling filter plant TYPE C with 3 pumps and 2 float switches

3-pump plant with 2 separate float switches for pump 2

Pump 1: Feed pump for trickling filter, pumps from the pump chamber to the trickling filter and into the primary treatment

Pump 2: Discharge pump, corresponds to clear water pump, pumps from the pump chamber into the final clarification

Pump 3: Excess sludge return, pumps from the final clarification into the primary treatment

SW1: Dry-running protection for P2 in the pump chamber

SW2: High-water alarm for P2 in the pump chamber

P1

Pump 1 pumps to the trickling filter and/or into the primary treatment, return flow, according to the preset time cycle. In addition, the flushing time takes place at night at 03:00.

P2

As soon as the lower external float switch, SW1 = dry-running protection, in the pump chamber is closed, pump 2 pumps from the pump chamber into the final clarification according to the preset time cycle.

If the upper external float switch in the pump chamber, SW2 = high-water alarm, is closed, pump 2 is put into continuous operation. In addition, an acoustic and visual warning message is issued, high water.

P3

Pump 3, sludge return, pumps from the final clarification into the primary treatment according to the preset time cycle.

Interaction of the Pumps

Only one pump runs at any time, except in the event of high water. Pump 1 has priority over pumps 2 and 3; pump 3 has priority over pump 2.

The switch-off point of SW1 for pump 2, clear water discharge, must be selected so that pump 1, feeding of the trickling filter, always has enough water left for the return flow.

B) Units of the trickling filter plant TYPE C with 2 pumps and 2 float switches

2-pump plant with 2 separate float switches for pump 2

Pump 1: active: NO

Pump 2: Discharge pump, corresponds to clear water pump, pumps from the pump chamber into the final clarification

Pump 3: Excess sludge return, pumps from the final clarification into the primary treatment

SW1: Dry-running protection for P2 in the pump chamber

SW2: High-water alarm for P2 in the pump chamber

P1

Deactivate

P2

As soon as the lower external float switch, SW1 = dry-running protection, in the pump chamber is closed, pump 2 pumps from the pump chamber into the final clarification according to the preset time cycle.

If the upper external float switch in the pump chamber, SW2 = high-water alarm, is closed, pump 2 is put into continuous operation. In addition, an acoustic and visual warning message is issued, high water.

P3

Pump 3, ESS return, pumps from the final clarification into the primary treatment and/or onto the trickling filter, return flow, according to the preset time cycle.

Interaction of the Pumps

Only one pump runs at any time, except in the event of high water.

C) Units of the trickling filter plant TYPE N with 2 pumps and 1 float switch**2-pump plant with 1 separate float switch for pump 2****Pump 1:** active: NO**Pump 2:** Discharge pump, corresponds to clear water pump, pumps from the pump chamber into the final clarification**Pump 3:** Excess sludge return, pumps from the final clarification into the primary treatment**SW2:** High-water alarm for P2 in the pump chamber

P1

Deactivate

P2

If the external float switch, SW2, in the pump chamber is open, pump 2 pumps from the pump chamber into the final clarification according to the preset time cycle.

If the external float switch in the pump chamber, SW2, is closed, pump 2 is put into continuous operation. In addition, an acoustic and visual warning message is issued, high water.

P3

Pump 3, ESS return, pumps from the final clarification into the primary treatment and/or onto the trickling filter, return flow, according to the preset time cycle.

Interaction of the Pumps

Only one pump runs at any time, except in the event of high water.

If pump 2 is a pump with an attached float switch, current monitoring for the pump concerned must be switched off; see Chapter 11.3.4.2.

If faults occur during operation of the plant, these are indicated visually and acoustically by the control unit. The red LED flashes and the buzzer sounds. The error message remains in the main display until the error is acknowledged; see Chapter 11.3.3.5.

The error message remains stored in the error logbook and can therefore also be evaluated later.

The control unit has a power failure alarm. In the event of a power failure, an alarm tone sequence is generated approximately every 30 seconds to alert the operator to the absence of the treatment function. When the power supply returns after the power failure, the device switches on again automatically.

11.1 Commissioning of the Control Unit



Before commissioning the plant, the primary treatment and final clarification tanks must be filled with water up to the outlet, and the pump chamber must be filled until the lower float switch floats up. The housing of the control unit must be closed if it has been opened. All required units must be connected to the control unit.



CAUTION! The **pump runtimes** must be read out from the previously used control unit and noted before it is switched off, so that they can be transferred to the new control unit during commissioning.

Before switching off the old control unit, please note the pump runtimes set there. Commissioning of the control unit begins by inserting the mains plug of the control unit. After the plug has been inserted, the control unit starts with a self-test lasting approx. 3 seconds, showing “booting system...” and the symbol of an hourglass . At the same time, the green LED lights up.

After the display “Fuse Check: values” with the message “Fuses o.k.”, the start message “AQUATO” appears on the display. The display Vx.xx.xx, e.g. V5.01.04, in the lower part of the message is the software version number.

During initial commissioning, the display “COMMISSIONING” then appears. During commissioning of the K-Pilot 14.5 control unit, the following must first be entered; see Chapters 11.3.2.4 as well as 11.3.3.1 and 11.3.3.6:

- Password, 4 digits, with password 1
or with password 2
 - Language
 - Date and time
- Basic plant type, here selection: **“TRICKLING FILTER C”** or **“TRICKLING FILTER N”**
 For **3-pump** plants, “Trickling Filter **C**” must be selected.
 For **2-pump** plants with 1 float switch, “Trickling Filter **N**” must be selected.

After these entries, the control unit automatically switches to manual operation; see Chapter 11.3.2.2. In manual operation, the different functions can be checked.

After manual operation has been ended, the control unit continues booting with the window “booting system...” and then “Fuse Check: values” with the message “Fuses o.k.”, before the start message “AQUATO” appears with the display of the selected plant type. Automatic operation then starts automatically immediately afterwards.



The commissioning technician must ensure that the parameter settings in the control unit have been made in such a way that they comply with the requirements, e.g. basic type and discharge class, from the approval and the water-law permit for the plant in which the control unit is to be used.

For trickling filter plants with 2 pumps, "PUMP 1" must be deactivated; see Chapter 11.3.4.2.

For all trickling filter plants, the pump runtimes still have to be adjusted. To do this, **please adopt the settings from the old control unit** and enter them in the "PUMP 1", "PUMP 2" and "PUMP 3" menus; see Chapter 11.3.4.2.

Commissioning is then complete.



CAUTION!

The pump runtimes must be read out from the previous control unit and transferred to the new one.

11.2 Main Display

In the standard display, the control unit shows the switching status of the plant and the units, e.g.:

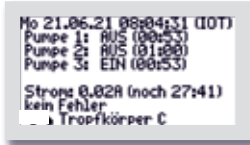

1st line: Date and time

2nd line: Switching status "PUMP 1:", "ON" or "OFF", and remaining runtime of this switching status

3rd line: Switching status "PUMP 2:", "ON" or "OFF", and remaining runtime of this switching status

4th line: Switching status "PUMP 3:", "ON" or "OFF", and remaining runtime of this switching status

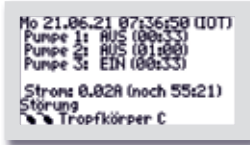

5th line: Blank line or, if a further pump has been selected, switching status "PUMP 4:", "ON" or "OFF", and remaining runtime of this switching status

6th line: Error display; otherwise "NO ERROR" if no fault message is present

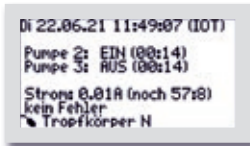

7th line: Float switch status up ρ / down \downarrow 1 float switch symbol for Trickling Filter N, 2 float switch symbols for Trickling Filter C; next to this, the selected plant type: "Trickling Filter C" or "Trickling Filter N"

If the  button is pressed in the standard display, an info window appears for approx. 3 seconds. The following is displayed in this window:

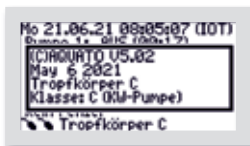

- Software version
- Date of the version
- Type Trickling Filter C or Trickling Filter N
- Discharge class C

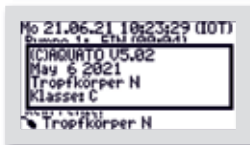

The exact display depends on the selected settings.

The  button can also be used in this menu to switch off the buzzer or the alarm. See also Chapter 11.3.3.5.

11.3 Menu

11.3.1 Menu Structure

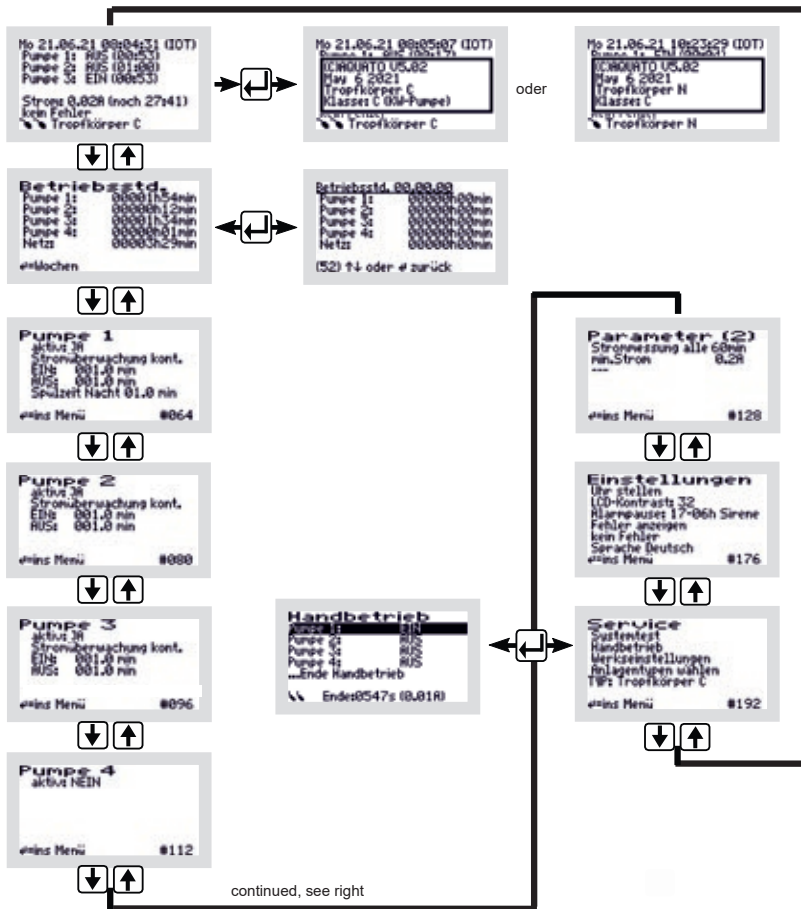



Figure 24: Menu structure for Tricking Filter C and Tricking Filter N

The exact display depends on the status of the plant and on the parameters that have been set. The different display variants are explained in more detail below.

You move from one menu to another using the   arrow keys. If you keep moving in the same direction, you will eventually return to the standard display.

To access the submenus in the displayed menu, the middle  button must be pressed. After pressing the  button, depending on the selected menu, either a window opens directly or the first menu item is marked by a black bar.

The individual items are selected using the   arrow keys. Pressing the  button takes you into the submenu or editing mode, if available.

11.3.2 “Service” Menu







The service menu is essentially intended for the service technician.

The following can be selected:

- System test / test operation
- Manual operation
- Factory settings, only with password 2
- Select plant types, only with password 1 or 2

11.3.2.1 System Test / Test Operation



In test operation, a check is carried out to determine whether the units are drawing current properly. If automatic test operation has been marked with the   arrow keys via the “SYSTEM TEST” menu item, it is called up with the  button. The “System Test” window offers the selection “CANCEL” or “START TEST”. These two options are selected with the   arrow keys in the lower line “(NEW)”. After “START TEST” has been selected and confirmed, the system test begins.

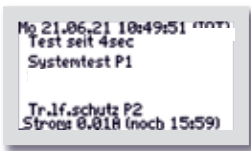

The test runs fully automatically. The individual functions are checked one after the other, each for approx. 15 seconds. If all units operate without errors, no alarm message appears.



Test operation can be cancelled by pressing the  button.

After all functions have been checked, test operation ends automatically and the interrupted automatic operation is continued.

11.3.2.2 Manual Operation



In manual operation of the K-Pilot 14.5 control unit, the activated pumps can be operated for the basic types Trickling Filter C and Trickling Filter N. The exact display depends on the parameters set during commissioning.



The   buttons can be used to select between the available parameters “PUMP 1” to “PUMP 4”; the pumps displayed differ depending on the default setting, by moving the black bar to the desired entry.



If, for example, “PUMP 1” is selected, it can be switched “ON” and “OFF” with the  button.

Manual operation is ended by moving the marking bar to the menu item “... End Manual Operation” using the   buttons and then confirming by pressing the  button. If manual operation is not ended with “... END MANUAL OPERATION”, the control unit automatically switches back to automatic operation 15 minutes after the last button was pressed.

After manual operation has been ended, the control unit continues the interrupted sequence in automatic operation.

11.3.2.3 Factory Settings

Under “FACTORY SETTINGS”, the limit for current faults can be changed. **Resetting** the control unit, which is also possible under Factory Settings, is **not permitted** during the entire operation. Access to the factory settings is only possible **with password 2**.





In the “FACTORY SETTINGS”, the following values can be changed/reset.



First enter password 1, or password 2 for more advanced settings, digit by digit and confirm each digit with the  button in order to access the menu.



The first window that opens is “MIN. CURRENT (mA)”. Here, the limit at which an error is displayed can be changed. The default setting is 200 mA. The lowest possible limit is 50 mA. The values can be changed digit by digit, starting on the left, in the lower line “(NEW)” using the   buttons. The selected value is accepted each time with the  button. After confirming the 3rd digit, the next window opens automatically.

The deletion options that follow are not permitted during the entire operating life of a small wastewater treatment plant. The prompts must be answered with “NO”.



**All prompts in the Factory Settings menu must be answered with “NO”.
The data must not be deleted..**





The window "CLEAR COUNTERS:" opens.

If "NO" is selected, the menus with the individual units are skipped and you go directly to the "CLEAR LOGBOOK" window.

→ Answer: "NO".



If "YES" is selected, the control unit switches to the individual units each time the  button is pressed. In the first following window, "P1", the counter for the runtime of P1 can be reset to zero using the   buttons by setting "YES" in the lower line.

→ Answer: "NO".



The same procedure can be followed in the windows that then appear: "P2", "P3", "P4", "MAINS".

→ Answer: "NO".



The last window to open in this menu is "CLEAR LOGBOOK". If "YES" is selected here, all entries and settings are deleted. The control unit then restarts with commissioning.

→ Answer: "NO".



CAUTION! The "Clear counters:" and "Clear logbook" processes must not be carried out during the entire operation of a plant, because the operating log must record the runtimes of the units.

11.3.2.4 Select Plant Type

In this menu, the plant type and plant size as well as further parameters required for operation can be set/changed.





Select the menu item "SELECT PLANT TYPES".



Then enter password 1 or password 2 digit by digit and confirm each digit with the  button in order to access the menu.





First, the "BASIC TYPE" of the plant is requested. Use the   buttons to select the desired type in the second line.



For operation as a trickling filter plant with 3 pumps and 2 float switches, please select "**TRICKLING FILTER C**". For operation as a trickling filter plant with 2 pumps and 2 float switches, also select "**TRICKLING FILTER C**". For operation as a trickling filter plant with 2 pumps and 1 float switch, please select "**TRICKLING FILTER N**". Confirm your selection with the  button.

The parameters for the pump runtimes are automatically preset by this selection, but must be readjusted. For this, you need the **runtimes from the previous control unit** in order to adopt the appropriate settings.

The menu item "SELECT PLANT TYPES" is now complete and the software returns to the "SERVICE" main menu. Use the   buttons to exit the menu.



CAUTION! The pump runtimes must be read out from the previous control unit and transferred to the new one.

11.3.3 “Settings” Menu





In the “SETTINGS” menu, the operator settings can be configured.



Press the  button to enter the menu and select the desired item.

11.3.3.1 Setting the Date and Time



To correct the time and/or date, select the line “SET CLOCK” using the   buttons. When the marking (= black bar) is on the desired entry, the window for adjusting the values is opened with the middle  button.



The first digit can be changed using the   buttons. When the correct value has been set, the digit is accepted with the middle button. All following digits are selected in the same way.

Input sequence: 2 digits each:

Day, month, year, hour, minute (DD.MM.YY_hh.mm)



The clock is quartz-controlled. It should also be checked during maintenance. Care should be taken to ensure that the clock is set correctly, as this makes maintenance evaluation easier.



Example: Changing the time from 13:20 to 13:26.

11.3.3.2 LCD Contrast



The LCD contrast can be optimized here. As a rule, no change is necessary.

11.3.3.3 Alarm Buzzer (“Alarm Pause”)



The acoustic alarm is switched off as standard from 5:00 p.m. to 6:00 a.m. During this time, errors are indicated visually only. This setting can be changed in the “ALARM PAUSE” menu item.



Caution:

No acoustic alarm is given during the period set here!



The sound for the alarm buzzer is set here. The selection options are: “SIREN”, “MELODY” and “OFF”.

The default setting is “SIREN”.



Caution:



With the “OFF” setting, no acoustic alarm is given!

11.3.3.4 Show Errors



The error logbook is called up via the menu item “SHOW ERRORS”.



The error logbook shows the last 30 error events with date and time. The   buttons are used to scroll through the logbook, and the  button is used to exit the menu.

Nothing can be deleted in the error logbook!

11.3.3.5 Clear Alarm



If a fault, an alarm, has occurred, the alarm message can be reset after marking the line "CLEAR ALARM" by pressing the  button. A window with the message "OK" then opens for approx. 1 second, and the display in the menu then changes to "NO ERROR". The red flashing of the LED goes out and the error message is cleared in the standard window.

The error message remains stored in the error logbook and can therefore also be evaluated later.

Note: If, in the event of a fault, the  button is pressed in the main display, which is the standard display during operation, the buzzer is switched off and the "CLEAR ALARM" window opens; after a short time, this automatically changes to the prompt "ARE YOU SURE?".

If this is answered with "YES", the error display is cleared and the red flashing of the LED goes out. The error message remains stored in the error logbook and can therefore also be evaluated later.

If the prompt "ARE YOU SURE?" is answered with "NO", the error message remains in the main display.

The info window with the details of the plant setting then opens for approx. 3 seconds.

11.3.3.6 Language



The language of the control unit is selected here. The password must be entered for this. The control unit is prepared for several languages. The languages currently programmed are:

- German
- English
- Swedish
- French
- Finnish

11.3.4 Further Menus with Displays or Settings



In the following menus, all current parameters of the plant can be displayed and, in some cases, set individually.

Adjustment may only be carried out by a qualified specialist, as otherwise the treatment performance of the plant may be reduced and the building authority approval may become invalid.

However, in order to change the displayed values, the password must first be entered.

To restore the original factory settings after changes have been made to the settings, e.g. changed runtimes, you can select the plant type again; see Chapter 11.3.2.4. The default values will then be set again.

11.3.4.1 Operating Hours Display



In the "OPERATING HOURS" menu, the operating hours of the respective units are displayed. The operating hours are counted up when the control unit has switched on the compressor, or a pump if applicable. The display is shown in hours and minutes.

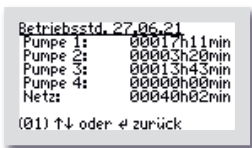

If the  button is pressed, the operating hours of the last, up to 52, weeks are displayed, operating log.

The last line shows the week, for example week 1, in which the values were saved, always on Sunday.

The  - buttons can be used to scroll from week to week.



Note:

This function only works correctly if the date and time have been set correctly.

11.3.4.2 Pump 1 to Pump 4

In the “PUMP 1” to “PUMP 4” menus, different parameters are displayed depending on the setting. The parameter “ACTIVE” is always present.



If the parameter “ACTIVE” is set to “NO”, no further parameters are displayed.



If required, the parameters can be changed individually. Press the button to enter the menu. The line to be changed is selected using the buttons. The menu item is called up with the button. The settings are changed using the buttons and confirmed with the button.

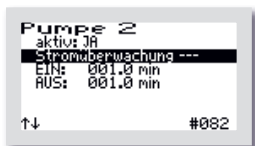

For “CURRENT MONITORING”, there are 3 options. It is preset as standard to “CONT.” (= continuous), but can also be set to “CYCLIC” or switched off completely; display: “---”. If the “CYCLIC” option has been selected, the period can be set in the “PARAMETER (2)” menu; see Chapter 11.3.4.3.

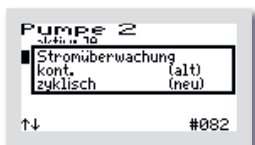

The “CYCLIC” option is used to check whether the pump is operating correctly in the case of pumps with an attached float switch. For this purpose, the number of cycles in which the function is checked before an error message occurs if the unit does not run during the test phase can be set. In the example, this is 24 cycles; see Chapter 11.3.4.3, “PARAMETER (2)”.

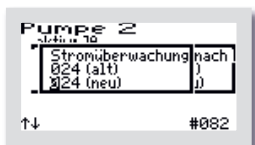

In addition, the currently flowing current is shown in the main display for monitoring purposes.

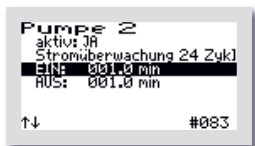

The pump runtimes are also set here. The “ON” switching time and the “OFF” switching time can each be set independently of one another. They then take place alternately.

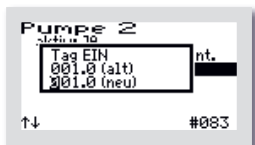







11.3.4.3 Parameter 2

The Parameter (1) menu is omitted for the trickling filter plant, as it has no function for this plant type. In the "PARAMETER (2)" menu, different parameters are displayed depending on the setting. The parameters "CURRENT MEASUREMENT" and "MIN. CURRENT" are always present.

When the control unit switches on a unit, e.g. a pump, it cannot be guaranteed with certainty that this unit is actually running. Overheating, defective cables or other defects may mean that the switching relay is switched on, but the unit is nevertheless not running. The control unit therefore monitors whether current is also flowing in the circuit. If the current falls below a limit value, which is set by default in the software to 0.2 A, a current alarm is displayed, e.g. "I_P1".



In this menu, current monitoring can be switched "OFF" or "ON". In the standard case, "CURRENT MEASUREMENT" is set to every "60" minutes. However, this parameter only has an effect if the "CYCLIC" setting for "CURRENT MONITORING" has been selected in one or more of the "PUMP 1" to "PUMP 4" menus; see Chapter 11.3.4.2. The time after which an error message is issued is then calculated from the cycle time, in the example = 60 minutes, and the number of cycles from the menu of the respective "PUMP", e.g. 24 cycles. Example: 24 cycles multiplied by 60 minutes results in an error message if the pump has not started at least once within a period of 1440 minutes, = 1 day.

If required, the parameters can be changed individually. Press the  button to enter the menu. The line to be changed is selected using the   buttons. The menu item is called up with the  button. The settings are changed using the   buttons and confirmed with the  button.

In addition, the currently flowing current is shown in the main display for monitoring purposes.

11.4 Default Settings

PUMP 1, 2, 3:	active: YES Current monitoring continuous ON: 1,0 minute OFF: 1,0 minute
PUMP 4:	active: NO

12 Operation as a Constructed Wetland Wastewater Treatment Plant

Operation of the small wastewater treatment plant must be carried out by the owner or by a competent person appointed by the owner, the operator.

After commissioning, the plant operates fully automatically. It is controlled by a PLC. The sequence and course of the phases are programmed in the control unit. The times adapted to the plant for pumping must be set in the control unit.

Units of the constructed wetland wastewater treatment plant

Pump 1: Feed pump

Pump 2: Clear water pump, with attached float switch, in the pump shaft, continuous runner

Pump 3: optional

SW1: High-water alarm for P1 in the feed shaft

SW2: High-water alarm for P2 in the pump shaft, pumping out the treated water

P1

Pump 1 pumps the water from the primary treatment onto the constructed wetland bed according to the preset time cycle.

P2

Pump 2 pumps the treated water from the pump shaft into the infiltration system or receiving water, controlled by the float switch.

Interaction of the Pumps

The two pumps run independently of one another.

If a pump is designed with an attached float switch, current monitoring for the pump concerned must be switched off; see Chapter 12.3.4.2.

If faults occur during operation of the plant, these are indicated visually and acoustically by the control unit. The red LED flashes and the buzzer sounds. The error message remains in the main display until the error is acknowledged; see Chapter 12.3.3.5.

The error message remains stored in the error logbook and can therefore also be evaluated later.

The control unit has a power failure alarm. In the event of a power failure, an alarm tone sequence is generated approximately every 30 seconds to alert the operator to the absence of the treatment function. When the power supply returns after the power failure, the device switches on again automatically.

12.1 Commissioning of the Control Unit



Before commissioning the plant, the primary treatment and final clarification tanks or the pump shaft must be filled with water at least up to the lower switching point of the respective float switch, and the housing of the control unit must be closed if it has been opened. All required units must be connected to the control unit.



CAUTION! The **pump runtimes** must be read out from the previously used **control unit and noted before it is switched off**, so that they can be **transferred** to the new control unit during commissioning.

Before switching off the old control unit, please note the pump runtimes set there. Commissioning of the control unit begins by inserting the mains plug of the control unit. After the plug has been inserted, the control unit starts with a self-test lasting approx. 3 seconds, showing “booting system...” and the symbol of an hourglass . At the same time, the green LED lights up.

After the display “Fuse Check: values” with the message “Fuses o.k.,” the start message “AQUATO” appears on the display. The display Vx.xx.xx, e.g. V5.01.04, in the lower part of the message is the software version number.

During initial commissioning, the display “COMMISSIONING” then appears. During commissioning of the K-Pilot 27.6 control unit, the following must first be entered; see Chapters 12.3.2.4 as well as 12.3.3.1 and 12.3.3.6:

- Password, 4 digits, with password 1
or with password 2
- Language
- Date and time
- Basic plant type, here selection: **“Constructed Wetland Plant”** for constructed wetland wastewater treatment plant

After these entries, the control unit automatically switches to manual operation; see Chapter 12.3.2.2. In manual operation, the different functions can be checked.

After manual operation has been ended, the message “booting system...” appears once again and then, after the display “Fuse Check: values” with the message “Fuses o.k.,” the start message “AQUATO” appears again with the display of the selected plant type. Automatic operation then starts automatically immediately afterwards.



The commissioning technician must ensure that the parameter settings in the control unit have been made in such a way that they comply with the requirements, e.g. basic type and discharge class, from the approval and the water-law permit for the plant in which the control unit is to be used.

For all constructed wetland wastewater treatment plants, the pump runtimes still have to be adjusted. To do this, **please adopt the settings from the old control unit** and enter them in the “PUMP 1” and “PUMP 2” menus; see Chapter 12.3.4.2.

Commissioning is then complete.



CAUTION!

The pump runtimes must be read out from the previous control unit and transferred to the new one.

12.2 Main Display

In the standard display, the control unit shows the switching status of the plant and the units, e.g.:

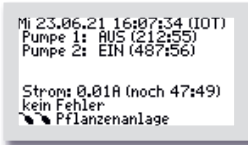

1st line: Date and time

2nd line: Switching status "PUMP 1:", "ON" or "OFF", and remaining runtime of this switching status

3rd line: Switching status "PUMP 2:", "ON" or "OFF", and remaining runtime of this switching status

4th line: Blank line or, if a further pump has been selected, switching status "PUMP 3:", "ON" or "OFF", and remaining runtime of this switching status

5th line: Blank line

6th line: Error display; otherwise "NO ERROR" if no fault message is present

7th line: Float switch status up ρ / down \downarrow ; next to this, the selected plant type: "Constructed Wetland Plant" for the constructed wetland wastewater treatment plant

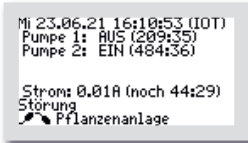

If the  button is pressed in the standard display, an info window appears for approx. 3 seconds. The following is displayed in this window:

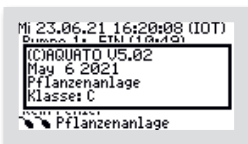

- Software version
- Date of the version
- Type "Constructed Wetland Plant" for constructed wetland wastewater treatment plant
- Discharge class C

The exact display depends on the selected settings.

The  button can also be used in this menu to switch off the buzzer or the alarm. See also Chapter 12.3.3.5.

12.3 Menu

12.4 Menu Structure

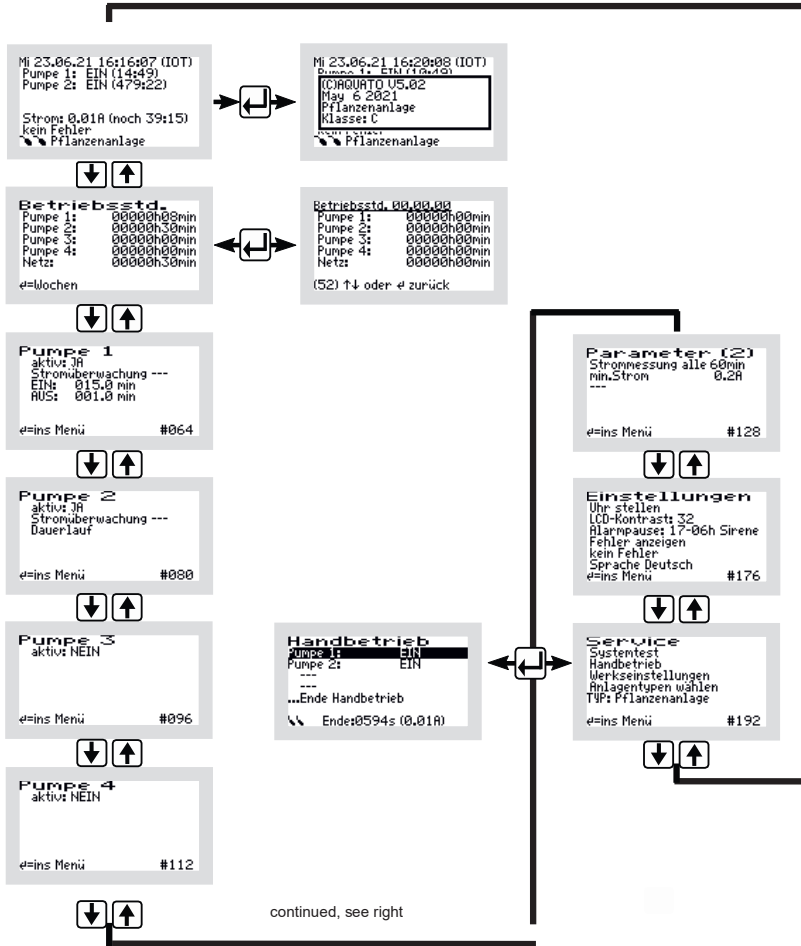



Figure 25: Menu structure for Tricking Filter C and Tricking Filter N

The exact display depends on the status of the plant and on the parameters that have been set. The different display variants are explained in more detail below.

You move from one menu to another using the   arrow keys. If you keep moving in the same direction, you will eventually return to the standard display.

To access the submenus in the displayed menu, the  middle button must be pressed. After pressing the  button, depending on the selected menu, either a window opens directly or the first menu item is marked by a black bar.

The individual items are selected using the   arrow keys. Pressing the  button takes you into the submenu or editing mode, if available.

12.4.1 “Service” Menu







The service menu is essentially intended for the service technician.

The following can be selected:

- System test / test operation
- Manual operation
- Factory settings, only with password 2
- Select plant types, only with password 1 or 2

12.4.1.1 System Test / Test Operation



In test operation, a check is carried out to determine whether the units are drawing current properly. If automatic test operation has been marked with the   arrow keys via the “SYSTEM TEST” menu item, it is called up with the  button. The “SYSTEM TEST” window offers the selection “CANCEL” or “START TEST”. These two options are selected with the   arrow keys in the lower line “(NEW)”. After “START TEST” has been selected and confirmed, the system test begins.

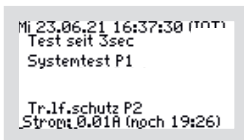

The test runs fully automatically. The individual functions are checked one after the other, each for approx. 15 seconds. If all units operate without errors, no alarm message appears.



Test operation can be cancelled by pressing the  button.

After all functions have been checked, test operation ends automatically and the interrupted automatic operation is continued.

12.4.1.2 Manual Operation



In manual operation of the K-Pilot 14.5 control unit, the activated pumps can be operated for the basic types Trickling Filter C and Trickling Filter N. The exact display depends on the parameters set during commissioning.



The   buttons can be used to select between the available parameters "PUMP 1" to "PUMP 4"; the pumps displayed differ depending on the default setting, by moving the black bar to the desired entry.



If, for example, "PUMP 1" is selected, it can be switched "ON" and "OFF" with the  button.

Manual operation is ended by moving the marking bar to the menu item "... End Manual Operation" using the   buttons and then confirming by pressing the  button.

If manual operation is not ended with "... END MANUAL OPERATION", the control unit automatically switches back to automatic operation 15 minutes after the last button was pressed.

After manual operation has been ended, the control unit continues the interrupted sequence in automatic operation.

12.4.1.3 Factory Settings

Under “FACTORY SETTINGS”, the limit for current faults can be changed. Resetting the control unit, which is also possible under Factory Settings, is **not permitted** during the entire operation. Access to the factory settings is **only possible with password 2**.

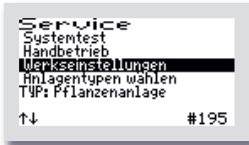



In the “FACTORY SETTINGS”, the following values can be changed/reset.



First enter password 1, or password 2 for more advanced settings, digit by digit and confirm each digit with the  button in order to access the menu.



The first window that opens is “MIN. CURRENT (mA)”. Here, the limit at which an error is displayed can be changed. The default setting is 200 mA. The lowest possible limit is 50 mA. The values can be changed digit by digit, starting on the left, in the lower line “(NEW)” using the   buttons. The selected value is accepted each time with the  button. After confirming the 3rd digit, the next window opens automatically.

The deletion options that follow are not permitted during the entire operating life of a small wastewater treatment plant. The prompts must be answered with “NO”.



**All prompts in the Factory Settings menu must be answered with “NO”.
The data must not be deleted.**





The window "CLEAR COUNTERS:" opens.

If "NO" is selected, the menus with the individual units are skipped and you go directly to the "CLEAR LOGBOOK" window.

→ Answer: "NO".



If "YES" is selected, the control unit switches to the individual units each time the  button is pressed. In the first following window, "P1", the counter for the runtime of P1 can be reset to zero using the   buttons by setting "YES" in the lower line.

→ Answer: "NO".

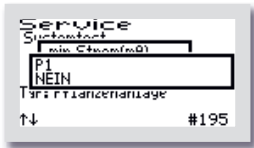

The same procedure can be followed in the windows that then appear: "P2", "P3", "P4", "MAINS".

→ Answer: "NO".

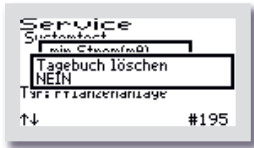

The last window to open in this menu is "CLEAR LOGBOOK". If "YES" is selected here, all entries and settings are deleted. The control unit then restarts with commissioning

→ Answer: "NO".



CAUTION! The "Clear counters:" and "Clear logbook" processes must not be carried out during the entire operation of a plant, because the operating log must record the runtimes of the units.

12.4.1.4 Select Plant Type

In this menu, the plant type and plant size as well as further parameters required for operation can be set/changed.





Select the menu item “SELECT PLANT TYPES”.



Then enter password 1 or password 2 digit by digit and confirm each digit with the  button in order to access the menu.



First, the “BASIC TYPE” of the plant is requested. Use the   buttons to select the desired type in the second line.

For operation as a constructed wetland wastewater treatment plant, please select the option “**Constructed Wetland Plant**”. Confirm your selection with the  button.

The parameters for the pump runtimes are automatically preset by this selection, but must be **readjusted**. For this, you need the **runtimes from the previous control unit** in order to adopt the appropriate settings.

The menu item “SELECT PLANT TYPES” is now complete and the software returns to the “SERVICE” main menu.



CAUTION! The pump runtimes must be read out from the previous control unit and transferred to the new one.







12.4.2 “Settings” Menu

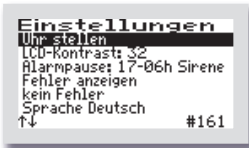

In the “SETTINGS” menu, the operator settings can be configured. Press the  button to enter the menu and select the desired item.

12.4.2.1 Setting the Date and Time



To correct the time and/or date, select the line “SET CLOCK” using the   buttons. When the marking (= black bar) is on the desired entry, the window for adjusting the values is opened with the  middle button. The first digit can be changed using the   buttons. When the correct value has been set, the digit is accepted with the  middle button. All following digits are selected in the same way.



Input sequence: 2 digits each:
Day, month, year, hour, minute (DD.MM.YY_hh.mm)



The clock is quartz-controlled. It should also be checked during maintenance. Care should be taken to ensure that the clock is set correctly, as this makes maintenance evaluation easier.



Example: Changing the time from 13:20 to 13:26.

12.4.2.2 LCD Contrast



The LCD contrast can be optimized here. As a rule, no change is necessary.

12.4.2.3 Alarm Buzzer (“Alarm Pause”)

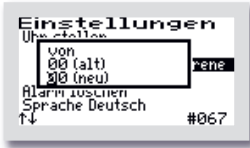

The acoustic alarm is switched off as standard from 5:00 p.m. to 6:00 a.m. During this time, errors are indicated visually only. This setting can be changed in the “ALARM PAUSE” menu item.



Caution:
No acoustic alarm is given during the period set here!



The sound for the alarm buzzer is set here. The selection options are: “SIREN”, “MELODY” and “OFF”.

The default setting is “SIREN”.

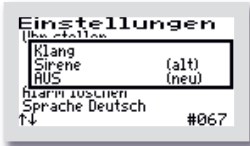



Caution: With the “OFF” setting, no acoustic alarm is given!

12.4.2.4 Show Errors



The error logbook is called up via the menu item “SHOW ERRORS”.



The error logbook shows the last 30 error events with date and time. The   buttons are used to scroll through the logbook, and the  button is used to exit the menu.

Nothing can be deleted in the error logbook!

12.4.2.5 Clear Alarm



If a fault, an alarm, has occurred, the alarm message can be reset after marking the line "CLEAR ALARM" by pressing the  button.

A window with the message "OK" then opens for approx. 1 second, and the display in the menu then changes to "NO ERROR". The red flashing of the LED goes out and the error message is cleared in the standard window.

The error message remains stored in the error logbook and can therefore also be evaluated later.

Note: If, in the event of a fault, the  button is pressed in the main display, which is the standard display during operation, the buzzer is switched off and the "CLEAR ALARM" window opens; after a short time, this automatically changes to the prompt "ARE YOU SURE?".

If this is answered with "YES", the error display is cleared and the red flashing of the LED goes out. The error message remains stored in the error logbook and can therefore also be evaluated later.

If the prompt "ARE YOU SURE?" is answered with "NO", the error message remains in the main display.

The info window with the details of the plant setting then opens for approx. 3 seconds.

12.4.2.6 Language



The language of the control unit is selected here. The password must be entered for this. The control unit is prepared for several languages. The languages currently programmed are:

- German
- English
- Swedish
- French
- Finnish

12.4.3 Further Menus with Displays or Settings



In the following menus, all current parameters of the plant can be displayed and, in some cases, set individually.

Adjustment may only be carried out by a qualified specialist, as otherwise the treatment performance of the plant may be reduced and the building authority approval may become invalid.

However, in order to change the displayed values, the password must first be entered.

To restore the original factory settings after changes have been made to the settings, e.g. changed runtimes, you can select the plant type again; see Chapter 12.3.2.4. The default values will then be set again.

12.4.3.1 Operating Hours Display



In the "OPERATING HOURS" menu, the operating hours of the respective units are displayed. The operating hours are counted up when the control unit has switched on the compressor, or a pump if applicable. The display is shown in hours and minutes.

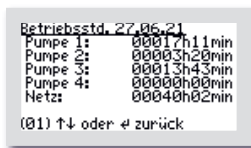

If the  button is pressed, the operating hours of the last, up to 52, weeks are displayed, operating log.

The last line shows the week, for example week 1, in which the values were saved, always on Sunday.

The   buttons can be used to scroll from week to week.



Note:

This function only works correctly if the date and time have been set correctly.

12.4.3.2 Pump 1 bis Pump 4

In the “PUMP 1” to “PUMP 4” menus, different parameters are displayed depending on the setting. The parameter “ACTIVE” is always present.



If the parameter “ACTIVE” is set to “NO”, no further parameters are displayed.

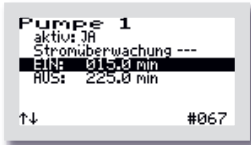

If required, the parameters can be changed individually. Press the button to enter the menu. The line to be changed is selected using the buttons. The menu item is called up with the button. The settings are changed using the buttons and confirmed with the button.

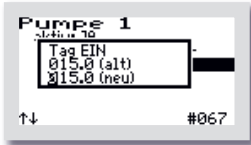

The pump runtimes are set here. The “ON” switching time and the “OFF” switching time can each be set independently of one another. They then take place alternately.

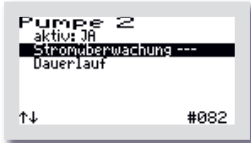

For “CURRENT MONITORING”, there are 3 options. It is preset as standard to “CONT.” (= continuous), but can also be set to “CYCLIC” or switched off completely; display: “---”. If the “CYCLIC” option has been selected, the period can be set in the “PARAMETER (2)” menu; see Chapter 12.3.4.3.

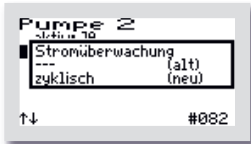

The “CYCLIC” option is used to check whether the pump is operating correctly in the case of pumps with an attached float switch. For this purpose, the number of cycles in which the function is checked before an error message occurs if the unit does not run during the test phase can be set. In the example, this is 24 cycles; see Chapter 12.3.4.3, “PARAMETER (2)”.

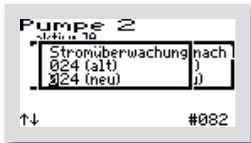

In addition, the currently flowing current is shown in the main display for monitoring purposes.

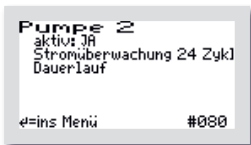







12.4.3.3 Parameter 2

The “Parameter 1” menu is omitted for the constructed wetland wastewater treatment plant, as it has no function for this plant type. In the “PARAMETER (2)” menu, different parameters are displayed depending on the setting. The parameters “CURRENT MEASUREMENT” and “MIN. CURRENT” are always present.

When the control unit switches on a unit, e.g. a pump, it cannot be guaranteed with certainty that this unit is actually running. Overheating, defective cables or other defects may mean that the switching relay is switched on, but the unit is nevertheless not running. The control unit therefore monitors whether current is also flowing in the circuit. If the current falls below a limit value, which is set by default in the software to 0.2 A, a current alarm is displayed, e.g. “I_P1”.



In this menu, current monitoring can be switched “OFF” or “ON”. In the standard case, “CURRENT MEASUREMENT” is set to every “60” minutes. However, this parameter only has an effect if the “CYCLIC” setting for “CURRENT MONITORING” has been selected in one or more of the “PUMP 1” to “PUMP 4” menus; see Chapter 12.3.4.2. The time after which an error message is issued is then calculated from the cycle time, in the example = 60 minutes, and the number of cycles from the menu of the respective “PUMP”, e.g. 24 cycles. Example: 24 cycles multiplied by 60 minutes results in an error message if the pump has not started at least once within a period of 1440 minutes, = 1 day.

If required, the parameters can be changed individually. Press the  button to enter the menu. The line to be changed is selected using the   buttons. The menu item is called up with the  button. The settings are changed using the   buttons and confirmed with the  button.

In addition, the currently flowing current is shown in the main display for monitoring purposes.

12.5 Default Settings

PUMP 1:	active: YES Current monitoring --- (OFF) ON: 15,0 minutes OFF: 225,0 minutes
PUMP 2:	active: YES Current monitoring --- (OFF) Continuous operation
PUMP 3 und 4:	active: NO

13 Error Messages and Troubleshooting

Display	Possible cause	Remedy
I Aer. The compressor has not drawn any current	- Compressor defective - Fuse defective	- Replace compressor - Replace fuse
I Clear W. The clear water pump / additional pump has not drawn any current	- Clear water pump defective - Fuse defective - Additional pump defective	- Replace clear water pump - Replace fuse - Replace additional pump
I Sludge The sludge pump has not drawn any current	- Sludge pump defective - Fuse defective	- Replace sludge pump - Replace fuse
I_P1 Pump P1 has not drawn any current	- Pump P1 defective - Fuse defective	- Replace pump P1 - Replace fuse
I_P2 Pump P2 has not drawn any current	- Pump P2 defective - Float switch stuck or defective - Fuse defective	- Replace pump P2 - Test and replace float switch - Replace fuse
I_P3 Pump P3 has not drawn any current	- Pump P3 defective - Fuse defective	- Replace pump P3 - Replace fuse
I_P4 Pump P4 has not drawn any current	- Pump P4 defective - Fuse defective	- Replace pump P4 - Replace fuse
p min Permissible pressure was undershot	- Hoses not connected or incorrectly connected - Hose connections or hose leaking / defective	- Check hose connections and hoses
p max Permissible pressure was exceeded	- Water level too high - Hose kinked - Aeration element soiled	- Check water level - Check hoses - Clean/replace aeration element
Battery	- Battery empty, defective or not inserted	- Insert new battery
Clock	- Clock not set	- Set clock

Display	Possible cause	Remedy
HW High water: after completion of clear water discharge, the float switch has not fallen below the switching point; high-water warning with "Float" control type	<ul style="list-style-type: none"> - Infiltration of extraneous water - Backwater from receiving water - Power failure - Float switch defective - Clear water pump blocked - Clear water hose defective 	<ul style="list-style-type: none"> - Locate and stop inflow - Possibly a one-off event - Establish permanent power supply - Replace float switch - Remove blockage - Replace clear water hose
HW ++ High water: float switch has floated up; temporary error, high-water warning with "Time" control type	<ul style="list-style-type: none"> - Infiltration of extraneous water - Backwater from receiving water - Power failure - Float switch defective - Clear water pump blocked - Clear water hose defective 	<ul style="list-style-type: none"> - Locate and stop inflow - Possibly a one-off event - Establish permanent power supply - Replace float switch - Remove blockage - Replace clear water hose
No float switch change	- Float switch has not switched for the preset number of days; the period can be set manually	<ul style="list-style-type: none"> - Check float switch - Possibly due to holiday mode
MAINS ON	- Mains power was switched on	
MAINS OFF > 15 min: Restart of the cycle	<ul style="list-style-type: none"> - Mains power was switched off - Power failure - Fuse tripped 	<ul style="list-style-type: none"> - Switch on power - Check fuse
Mains interruption < 15 min and > 1 min: Restart of the cycle < 1 min: Cycle is continued	<ul style="list-style-type: none"> - Mains power was switched off - Power failure - Fuse tripped 	<ul style="list-style-type: none"> - Switch on power - Check fuse

If the measures listed above do not eliminate the fault, please contact your maintenance service or installation company.



When working on the compressor and pumps, and before opening the control unit, the mains plug must be disconnected. Secure the plant against being switched on again during the work.

14 Technical Data

Temperature range, operation	0 °C ... + 40 °C
Temperature range, storage	0°C ... + 50 °C
Humidity, operation and storage	0 ... 90 % RH, non-condensing
Protection class	double-insulated
Degree of protection	IP 54
Approx. dimensions, without cable glands, socket	200 mm x 120 mm x 80 mm
Mounting	Wall mounting with screws
Housing material	Plastic, light grey
Mains connection (L1, N, PE), cable approx. 1.5 m long with moulded earthed plug	230 V~ 50 Hz ± 10 %
Units, compressor / pumps, max. power with 3.15 A fuse	230 V / 50 Hz P < 0,7 kVA
Internal fuse, max. 1.5 W	1 x 5 AT, max. 6,3 AT
Overtemperature protection of the pumps	Via thermal contact in the motor, in series with the motor
Current monitoring via a current transformer	Max. 10 A, type 10 % of full scale value (10 A)
Power consumption of control unit	Typ 5 VA
Float input, switches against N	Control voltage 230 V~, I < 10 mA
Required upstream fuse(s)	Max. 1 x 16 A G
Cable cross-section	1.5 mm ² , with ferrule
Alarm relay	max. contact voltage: 230 V~ max. contact current: 8 A; AC1
Internal buzzer	Typ 70 dB(A)
Displays	Graphical LCD display 128 x 64 pixels 1 x green LED 1 x red LED

15 Operating Log

In order to ensure smooth long-term operation of your small wastewater treatment plant, the following checks by the operator are prescribed.

Operation of the plant, fault messages	Daily
Reading the operating hours * Checking the inlets and outlets for blockages Visual inspection of the outlet for sludge discharge Removal of floating sludge, if necessary Visual inspection of the trickling filter surface for puddle formation Checking the distributor device on/above the trickling filter In the case of subsequent infiltration, the requirements according to DIN 4261-5 for operation must be observed	Monthly
Drinking water consumption	Annually

* The written entry of the operating hours in the operating log can be omitted for AQUATO plants, as the control unit records the operating hours in an electronic logbook.

Identified defects or faults must be entered in the **operating log**, enclosed with the plant, reported to the maintenance service and rectified without delay.

Reading the Operating Hours



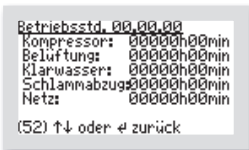

In the OPERATING HOURS chapter of your control unit, the operating hours of the respective units are displayed. The operating hours are counted up when the control unit has switched on the compressor, or the pump if applicable. The display is shown in hours and minutes.

If the  button is pressed, the operating hours of the last, up to 52, weeks are displayed, operating log.



The last line shows the calendar week, for example CW 52, in which the values were saved, always on Sunday.

The   buttons can be used to scroll from week to week.



Note:

This function only works correctly if the date and time have been set correctly.

The data you record is important for the maintenance of your small wastewater treatment plant. The more carefully you carry out these checks, the easier it will be for your trusted specialist company!

16 Decommissioning and Disposal



Ensure that only qualified specialist personnel with suitable safety equipment have access. Make sure that the general safety regulations and the safety regulations at the installation site are observed.



Before starting temporary decommissioning and final dismantling, switch off the plant by disconnecting the mains plug. Secure the plant against being switched on again.

16.1 Temporary Decommissioning

Temporary decommissioning is required for maintenance work or replacement of the following components:

- Control unit
- Compressor
- Rotary valve
- Wear parts, e.g. membrane aerators, pumps

16.2 Dismantling of the Complete Plant

The complete dismantling of the entire plant may only be carried out by qualified specialist personnel.

Before starting dismantling, disconnect the plant from the power supply.

Disconnect the hoses and cables at the control unit/control cabinet.

Pull the hoses and, if present, the float switch cable out towards the tank.

Remove the tank.

Remove the control unit/control cabinet.

16.3 Disposal

Ensure that the plant is disposed of properly.

17 Addresses

Manufacturer	
Company	AQUATO® Umwelttechnologien GmbH
Address	Ernstmeierstr. 24
	32052 Herford
Telephone	+49(0)5221 / 10 21 9-0
Internet	www.aquato.de
Email	info@aquato.de

Purchase / installation of the plant from	
Company	
Address	
Telephone	
Fax	
Internet	
Email	

Your maintenance company	
Company	
Address	
Telephone	
Fax	
Internet	
Email	

The warranty will void if operation and maintenance of the sewage treatment plant are not carried out in accordance with the instructions and specifications of the operating manual.

VERSION 05.2026

Installation Company:

AQUATO® Umwelttechnologien GmbH

Ernstmeierstr. 24 fon +49 5221 10219-0 www.aquato.de
32052 Herford fax +49 5221 10219-20 info@aquato.de